

Copyright Notice:

No part of this documentation may be reproduced, transcribed, transmitted, or translated in any language, in any form or by any means, except duplication of documentation by the purchaser for backup purpose, without written consent of ASRock Inc.

Products and corporate names appearing in this documentation may or may not be registered trademarks or copyrights of their respective companies, and are used only for identification or explanation and to the owners' benefit, without intent to infringe.

Disclaimer:

Specifications and information contained in this documentation are furnished for informational use only and subject to change without notice, and should not be constructed as a commitment by ASRock. ASRock assumes no responsibility for any errors or omissions that may appear in this documentation.

With respect to the contents of this documentation, ASRock does not provide warranty of any kind, either expressed or implied, including but not limited to the implied warranties or conditions of merchantability or fitness for a particular purpose.

In no event shall ASRock, its directors, officers, employees, or agents be liable for any indirect, special, incidental, or consequential damages (including damages for loss of profits, loss of business, loss of data, interruption of business and the like), even if ASRock has been advised of the possibility of such damages arising from any defect or error in the documentation or product.

The terms HDMI™ and HDMI High-Definition Multimedia Interface, and the HDMI logo are trademarks or registered trademarks of HDMI Licensing LLC in the United States and other countries.



This device complies with Part 15 of the FCC Rules. Operation is subject to the following two conditions:

- (1) this device may not cause harmful interference, and
- (2) this device must accept any interference received, including interference that may cause undesired operation.

CALIFORNIA, USA ONLY

The Lithium battery adopted on this motherboard contains Perchlorate, a toxic substance controlled in Perchlorate Best Management Practices (BMP) regulations passed by the California Legislature. When you discard the Lithium battery in California, USA, please follow the related regulations in advance.

“Perchlorate Material-special handling may apply, see www.dtsc.ca.gov/hazardouswaste/perchlorate”

The terms HDMI™ and HDMI High-Definition Multimedia Interface, and the HDMI logo are trademarks or registered trademarks of HDMI Licensing LLC in the United States and other countries.



Motherboard Layout

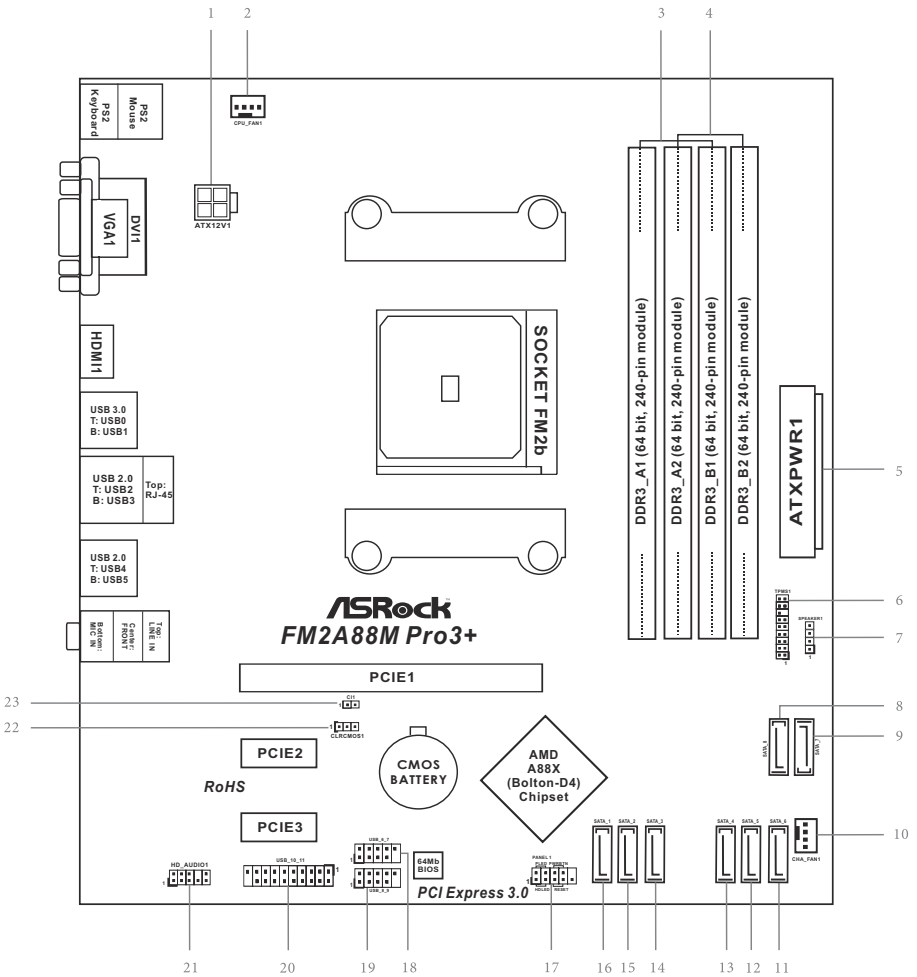

No.	Description
1	ATX 12V Power Connector (ATX12V1)
2	CPU Fan Connector (CPU_FAN1)
3	2 x 240-pin DDR3 DIMM Slots (DDR3_A1, DDR3_B1)
4	2 x 240-pin DDR3 DIMM Slots (DDR3_A2, DDR3_B2)
5	ATX Power Connector (ATXPWR1)
6	TPM Header (TPMS1)
7	Chassis Speaker Header (SPEAKER1)
8	SATA3 Connector (SATA_8)
9	SATA3 Connector (SATA_7)
10	Chassis Fan Connector (CHA_FAN1)
11	SATA3 Connector (SATA_6)
12	SATA3 Connector (SATA_5)
13	SATA3 Connector (SATA_4)
14	SATA3 Connector (SATA_3)
15	SATA3 Connector (SATA_2)
16	SATA3 Connector (SATA_1)
17	System Panel Header (PANEL1)
18	USB 2.0 Header (USB_6_7)
19	USB 2.0 Header (USB_8_9)
20	USB 3.0 Header (USB_10_11)
21	Front Panel Audio Header (HD_AUDIO1)
22	Clear CMOS Jumper (CLRCMOS1)
23	Chassis Intrusion Header (CI1)

I/O Panel

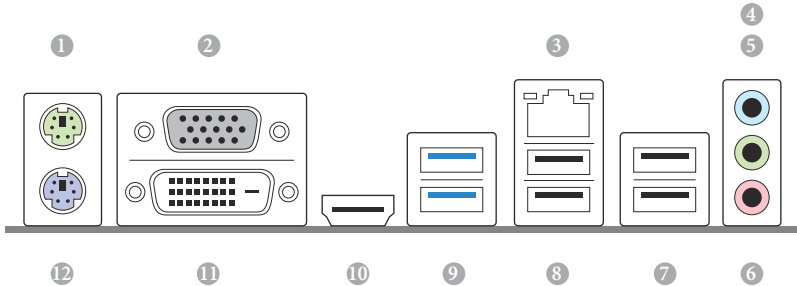

No.	Description	No.	Description
1	PS/2 Mouse Port	7	USB 2.0 Ports (USB4_5)**
2	D-Sub Port	8	USB 2.0 Ports (USB23)**
3	LAN RJ-45 Port*	9	USB 3.0 Ports (USB_01) (AMD A88X (Bolton-D4))
4	Line In (Light Blue)	10	HDMI Port
5	Front Speaker (Lime)	11	DVI-D Port
6	Microphone (Pink)	12	PS/2 Keyboard Port

* There are two LEDs on the LAN port. Please refer to the table below for the LAN port LED indications.

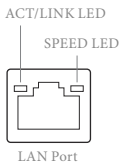

Activity / Link LED		Speed LED	
Status	Description	Status	Description
Off	No Link	Off	10Mbps connection
Blinking	Data Activity	Orange	100Mbps connection
On	Link	Green	1Gbps connection

** It is recommended to install the USB Keyboard/Mouse cable to USB 2.0 ports (USB23 or USB4_5) instead of USB 3.0 ports.

1. Introduction

Thank you for purchasing ASRock **FM2A88M Pro3+** motherboard, a reliable motherboard produced under ASRock's consistently stringent quality control. It delivers excellent performance with robust design conforming to ASRock's commitment to quality and endurance.

This Quick Installation Guide contains introduction of the motherboard and step-by-step installation guide. More detailed information of the motherboard can be found in the user manual presented in the Support CD.



Because the motherboard specifications and the BIOS software might be updated, the content of this manual will be subject to change without notice. In case any modifications of this manual occur, the updated version will be available on ASRock website without further notice. You may find the latest VGA cards and CPU support lists on ASRock website as well.

ASRock website <http://www.asrock.com>

If you require technical support related to this motherboard, please visit our website for specific information about the model you are using.

www.asrock.com/support/index.asp

1.1 Package Contents

ASRock **FM2A88M Pro3+** Motherboard (Micro ATX Form Factor)

ASRock **FM2A88M Pro3+** Quick Installation Guide

ASRock **FM2A88M Pro3+** Support CD

2 x Serial ATA (SATA) Data Cables (Optional)

1 x I/O Panel Shield

1.2 Specifications

Platform	<ul style="list-style-type: none"> - Micro ATX Form Factor - Solid Capacitor design - High Density Glass Fabric PCB
CPU	<ul style="list-style-type: none"> - Supports Socket FM2+ 95W / FM2 100W processors
Chipset	<ul style="list-style-type: none"> - AMD A88X (Bolton-D4)
Memory	<ul style="list-style-type: none"> - Dual Channel DDR3 Memory Technology - 4 x DDR3 DIMM Slots - Supports DDR3 2400+(OC)/2133/1866/1600/1333/1066 non-ECC, un-buffered memory (see CAUTION 1) - Max. capacity of system memory: 64GB (see CAUTION 2) - Supports Intel® Extreme Memory Profile (XMP) 1.3 / 1.2 - Supports AMD Memory Profile Technology (AMP) up to AMP 2400
Expansion Slot	<ul style="list-style-type: none"> - 1 x PCI Express 3.0 x16 Slot (PCIe1 @ x16 mode) * PCIe 3.0 is only supported with FM2+ CPU. With FM2 CPU, it only supports PCIe 2.0. - 2 x PCI Express 2.0 x1 Slots - Supports AMD Dual Graphics
Graphics	<ul style="list-style-type: none"> - Integrated AMD Radeon™ R7/R5 Series Graphics in A-series APU - DirectX 11.1, Pixel Shader 5.0 with FM2+ CPU. DirectX 11, Pixel Shader 5.0 with FM2 CPU. - Max. shared memory 2GB - Three graphics output options: D-Sub, DVI-D and HDMI Ports - Supports Triple Monitor - Supports HDMI with max. resolution up to 4K × 2K (4096x2160) @ 24Hz * Only FM2+ APU can support up to 4096x2160 resolution display via HDMI port - Supports Dual-link DVI-D with max. resolution up to 2560x1600 @ 60Hz - Supports D-Sub with max. resolution up to 1920x1200 @ 60Hz - Supports Auto Lip Sync, Deep Color (12bpc), xvYCC and HBR (High Bit Rate Audio) with HDMI Port (Compliant HDMI monitor is required) (see CAUTION 3) - Supports Blu-ray Stereoscopic 3D with HDMI Port

	<ul style="list-style-type: none"> - Supports AMD Steady Video™ 2.0: New video post processing capability for automatic jitter reduction on home/online video - Supports HDCP with DVI-D and HDMI Ports - Supports Full HD 1080p Blu-ray (BD) playback with DVI-D and HDMI Ports
Audio	<ul style="list-style-type: none"> - 5.1 CH HD Audio (Realtek ALC662 Audio Codec) - Supports Surge Protection (ASRock Full Spike Protection) - ELNA Audio Caps
LAN	<ul style="list-style-type: none"> - PCIE x1 Gigabit LAN 10/100/1000 Mb/s - Realtek RTL8111GR - Supports Wake-On-WAN - Supports Wake-On-LAN - Supports Lightning/ESD Protection (ASRock Full Spike Protection) - Supports LAN Cable Detection - Supports Energy Efficient Ethernet 802.3az - Supports PXE
Rear Panel I/O	<ul style="list-style-type: none"> - 1 x PS/2 Mouse Port - 1 x PS/2 Keyboard Port - 1 x D-Sub Port - 1 x DVI-D Port - 1 x HDMI Port - 4 x USB 2.0 Ports (Supports ESD Protection (ASRock Full Spike Protection)) - 2 x USB 3.0 Ports (AMD A88X (Bolton-D4)) (Supports ESD Protection (ASRock Full Spike Protection)) - 1 x RJ-45 LAN Port with LED (ACT/LINK LED and SPEED LED) - HD Audio Jacks: Line in / Front Speaker / Microphone
Storage	<ul style="list-style-type: none"> - 8 x SATA3 6.0 Gb/s Connectors, support RAID (RAID 0, RAID 1, RAID 5 and RAID 10), NCQ, AHCI and Hot Plug
Connector	<ul style="list-style-type: none"> - 1 x Chassis Intrusion Header - 1 x TPM Header - 1 x CPU Fan Connector (4-pin) - 1 x Chassis Fan Connector (4-pin) - 1 x 24 pin ATX Power Connector - 1 x 4 pin 12V Power Connector - 1 x Front Panel Audio Connector - 2 x USB 2.0 Headers (Support 4 USB 2.0 ports) (Supports ESD Protection (ASRock Full Spike Protection))

	<ul style="list-style-type: none"> - 1 x USB 3.0 Header by AMD A88X (Bolton-D4) (Supports 2 USB 3.0 ports) (Supports ESD Protection (ASRock Full Spike Protection))
BIOS Feature	<ul style="list-style-type: none"> - 64Mb AMI UEFI Legal BIOS with GUI support - Supports "Plug and Play" - ACPI 1.1 Compliant wake up events - Supports jumperfree - SMBIOS 2.3.1 support - DRAM, CPU Voltage multi-adjustment
Hardware Monitor	<ul style="list-style-type: none"> - CPU temperature sensing - Chassis temperature sensing - CPU Fan Tachometer - Chassis Fan Tachometer - CPU/Chassis Quiet Fan - CPU/Chassis Fan multi-speed control - CASE OPEN detection - Voltage monitoring: +12V, +5V, +3.3V, Vcore
OS	<ul style="list-style-type: none"> - Microsoft® Windows® 10 32-bit / 10 64-bit / 8.1 32-bit / 8.1 64-bit / 8 32-bit / 8 64-bit / 7 32-bit / 7 64-bit * For the updated Windows® 10 driver, please visit ASRock's website for details: http://www.asrock.com * Carrizo FM2r2 processor supports Windows® 10 64-bit / 8.1 64-bit / 7 32-bit / 7 64-bit only.
Certifications	<ul style="list-style-type: none"> - FCC, CE, WHQL - ErP/EuP ready (ErP/EuP ready power supply is required)

* For detailed product information, please visit our website: <http://www.asrock.com>

WARNING

Please realize that there is a certain risk involved with overclocking, including adjusting the setting in the BIOS, applying Untied Overclocking Technology, or using third-party overclocking tools. Overclocking may affect your system's stability, or even cause damage to the components and devices of your system. It should be done at your own risk and expense. We are not responsible for possible damage caused by overclocking.

CAUTION!

1. Whether 2400/2133/1866/1600MHz memory speed is supported depends on the CPU you adopt. If you want to adopt DDR3 2400/2133/1866/1600 memory module on this motherboard, please refer to the memory support list on our website for the compatible memory modules.
ASRock website <http://www.asrock.com>
2. Due to the operating system limitation, the actual memory size may be less than 4GB for the reservation for system usage under Windows® 10 / 8.1 / 8 / 7. For Windows® 64-bit OS with 64-bit CPU, there is no such limitation.
3. xvYCC and Deep Color are only supported under Windows® 10 64-bit / 10 / 8.1 64-bit / 8.1 / 8 64-bit / 8 / 7 64-bit / 7. Deep Color mode will be enabled only if the display supports 12bpc in EDID. HBR is supported under Windows® 10 64-bit / 10 / 8.1 64-bit / 8.1 / 8 64-bit / 8 / 7 64-bit / 7.

2. Installation

This is a Micro ATX form factor motherboard. Before you install the motherboard, study the configuration of your chassis to ensure that the motherboard fits into it.

Pre-installation Precautions

Take note of the following precautions before you install motherboard components or change any motherboard settings.



Before you install or remove any component, ensure that the power is switched off or the power cord is detached from the power supply. Failure to do so may cause severe damage to the motherboard, peripherals, and/or components.

1. Unplug the power cord from the wall socket before touching any component.
2. To avoid damaging the motherboard components due to static electricity, NEVER place your motherboard directly on the carpet or the like. Also remember to use a grounded wrist strap or touch a safety grounded object before you handle components.
3. Hold components by the edges and do not touch the ICs.
4. Whenever you uninstall any component, place it on a grounded anti-static pad or in the bag that comes with the component.
5. When placing screws into the screw holes to secure the motherboard to the chassis, please do not over-tighten the screws! Doing so may damage the motherboard.

2.1 CPU Installation

Step 1. Unlock the socket by lifting the lever up to a 90° angle.

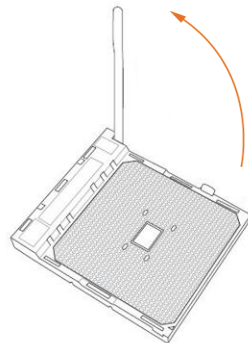

- Step 2. Position the CPU directly above the socket such that the CPU corner with the golden triangle matches the socket corner with a small triangle.
- Step 3. Carefully insert the CPU into the socket until it fits in place.



The CPU fits only in one correct orientation. DO NOT force the CPU into the socket to avoid bending of the pins.

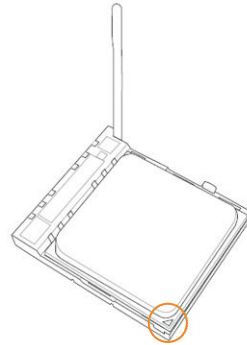

- Step 4. When the CPU is in place, press it firmly on the socket while you push down the socket lever to secure the CPU. The lever clicks on the side tab to indicate that it is locked.



2.2 Installation of CPU Fan and Heatsink

After you install the CPU into this motherboard, it is necessary to install a larger heatsink and cooling fan to dissipate heat. You also need to spray thermal grease between the CPU and the heatsink to improve heat dissipation. Make sure that the CPU and the heatsink are securely fastened and in good contact with each other. Then connect the CPU fan to the CPU FAN connector (CPU_FAN1, see Page 2, No. 2). For proper installation, please kindly refer to the instruction manuals of the CPU fan and the heatsink.

2.3 Installation of Memory Modules (DIMM)

This motherboard provides four 240-pin DDR3 (Double Data Rate 3) DIMM slots, and supports Dual Channel Memory Technology.



1. For dual channel configuration, you always need to install identical (the same brand, speed, size and chip-type) DDR3 DIMM pairs.
2. It is unable to activate Dual Channel Memory Technology with only one or three memory module installed.
3. It is not allowed to install a DDR or DDR2 memory module into a DDR3 slot; otherwise, this motherboard and DIMM may be damaged.
4. If you adopt DDR3 2400/2133/1866/1600 memory modules on this motherboard, it is recommended to install them on DDR3_A2 and DDR3_B2 slots.

Dual Channel Memory Configuration

Priority	DDR3_A1	DDR3_A2	DDR3_B1	DDR3_B2
1	Populated		Populated	
2		Populated		Populated
3	Populated	Populated	Populated	Populated



The DIMM only fits in one correct orientation. It will cause permanent damage to the motherboard and the DIMM if you force the DIMM into the slot at incorrect orientation.

1

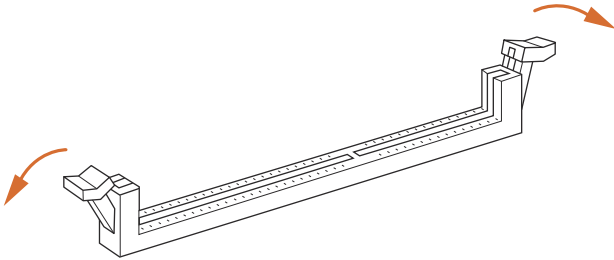

2

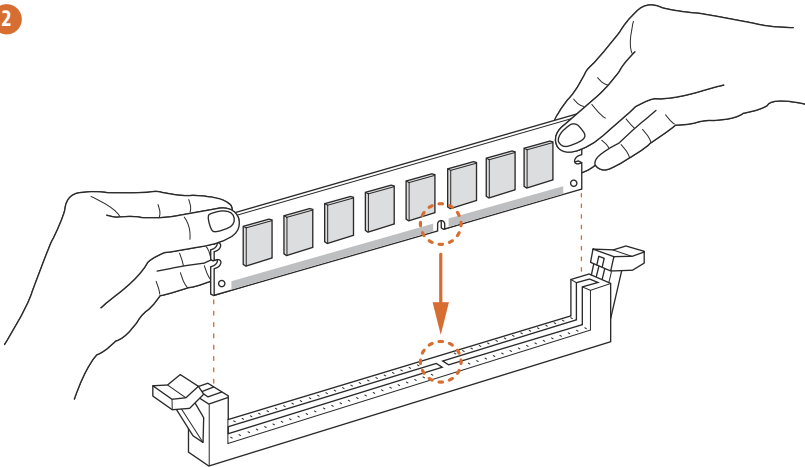

3

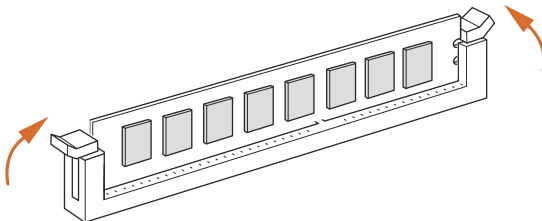

2.4 Expansion Slots (PCI Express Slots)

There are 3 PCI Express slots on this motherboard.



Before installing an expansion card, please make sure that the power supply is switched off or the power cord is unplugged. Please read the documentation of the expansion card and make necessary hardware settings for the card before you start the installation.

PCIE Slots:



PCIE1 (PCIe 3.0 x16 slot) is used for PCI Express x16 lane width graphics cards.

PCIE2 / PCIE3 (PCIe 2.0 x1 slot) is used for PCI Express cards with x1 lane width cards.

2.5 Jumpers Setup

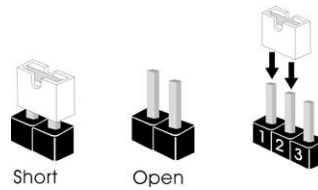
The illustration shows how jumpers are setup. When the jumper cap is placed on pins, the jumper is “Short”. If no jumper cap is placed on pins, the jumper is “Open”. The illustration shows a 3-pin jumper whose pin1 and pin2 are “Short” when jumper cap is placed on these 2 pins.



Jumper	Setting	Description
Clear CMOS Jumper (CLRCMOS1) (see p.2, No. 22)	<div style="display: flex; justify-content: space-around;"> <div style="text-align: center;"> 1_2  Default </div> <div style="text-align: center;"> 2_3  Clear CMOS </div> </div>	

Note: CLRCMOS1 allows you to clear the data in CMOS. To clear and reset the system parameters to default setup, please turn off the computer and unplug the power cord from the power supply. After waiting for 15 seconds, use a jumper cap to short pin2 and pin3 on CLRCMOS1 for 5 seconds. However, please do not clear the CMOS right after you update the BIOS. If you need to clear the CMOS when you just finish updating the BIOS, you must boot up the system first, and then shut it down before you do the clear-CMOS action. Please be noted that the password, date, time, user default profile, 1394 GUID and MAC address will be cleared only if the CMOS battery is removed.



If you clear the CMOS, the case open may be detected. Please adjust the BIOS option “Clear Status” to clear the record of previous chassis intrusion status.

2.6 Onboard Headers and Connectors



Onboard headers and connectors are NOT jumpers. Do NOT place jumper caps over these headers and connectors. Placing jumper caps over the headers and connectors will cause permanent damage of the motherboard!

Serial ATA3 Connectors

- (SATA_1: see p.2, No. 16)
- (SATA_2: see p.2, No. 15)
- (SATA_3: see p.2, No. 14)
- (SATA_4: see p.2, No. 13)
- (SATA_5: see p.2, No. 12)
- (SATA_6: see p.2, No. 11)
- (SATA_7: see p.2, No. 9)
- (SATA_8: see p.2, No. 8)



These eight Serial ATA3 (SATA3) connectors support SATA data cables for internal storage devices. The current SATA3 interface allows up to 6.0 Gb/s data transfer rate.

USB 2.0 Headers

- (9-pin USB_6_7)
- (see p.2 No. 18)
- (9-pin USB_8_9)
- (see p.2 No. 19)

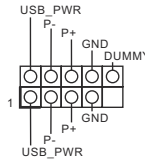

Besides four default USB 2.0 ports on the I/O panel, there are two USB 2.0 headers on this motherboard. Each USB 2.0 header can support two USB 2.0 ports.

USB 3.0 Header

- (19-pin USB_10_11)
- (see p.2, No. 20)

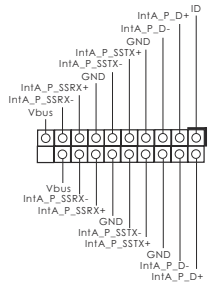

Besides two default USB 3.0 ports on the I/O panel, there is one USB 3.0 header on this motherboard. This USB 3.0 header can support two USB 3.0 ports.

Front Panel Audio Header

(9-pin HD_AUDIO1)

(see p.2 No. 21)

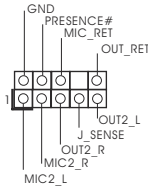

This is an interface for the front panel audio cable that allows convenient connection and control of audio devices.



1. High Definition Audio supports Jack Sensing, but the panel wire on the chassis must support HDA to function correctly. Please follow the instruction in our manual and chassis manual to install your system.
2. If you use AC'97 audio panel, please install it to the front panel audio header as below:
 - A. Connect Mic_IN (MIC) to MIC2_L.
 - B. Connect Audio_R (RIN) to OUT2_R and Audio_L (LIN) to OUT2_L.
 - C. Connect Ground (GND) to Ground (GND).
 - D. MIC_RET and OUT_RET are for HD audio panel only. You don't need to connect them for AC'97 audio panel.
 - E. To activate the front mic.

For Windows® 8.1 / 8.1 64-bit / 8 / 8 64-bit / 7 / 7 64-bit 64-bit OS:
Go to the "FrontMic" Tab in the Realtek Control panel. Adjust "Recording Volume".

System Panel Header

(9-pin PANEL1)

(see p.2 No. 17)

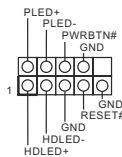

This header accommodates several system front panel functions.



Connect the power switch, reset switch and system status indicator on the chassis to this header according to the pin assignments below. Note the positive and negative pins before connecting the cables.

PWRBTN (Power Switch):

Connect to the power switch on the chassis front panel. You may configure the way to turn off your system using the power switch.

RESET (Reset Switch):

Connect to the reset switch on the chassis front panel. Press the reset switch to restart the computer if the computer freezes and fails to perform a normal restart.

PLED (System Power LED):

Connect to the power status indicator on the chassis front panel. The LED is on when the system is operating. The LED keeps blinking when the system is in S1 sleep state. The LED is off when the system is in S3/S4 sleep state or powered off (S5).

HDLED (Hard Drive Activity LED):

Connect to the hard drive activity LED on the chassis front panel. The LED is on when the hard drive is reading or writing data.

The front panel design may differ by chassis. A front panel module mainly consists of power switch, reset switch, power LED, hard drive activity LED, speaker and etc. When connecting your chassis front panel module to this header, make sure the wire assignments and the pin assignments are matched correctly.

Chassis Speaker Header

(4-pin SPEAKER 1)
(see p.2 No. 7)

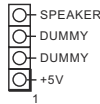

Please connect the chassis speaker to this header.

Chassis Fan Connector

(4-pin CHA_FAN1)
(see p.2 No. 10)

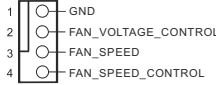

Please connect the fan cable to the fan connector and match the black wire to the ground pin. CHA_FAN1 fan speed can be controlled through UEFI or A-Tuning.

CPU Fan Connector

(4-pin CPU_FAN1)
(see p.2 No. 2)

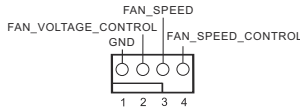

Please connect the CPU fan cable to the connector and match the black wire to the ground pin.



Though this motherboard provides 4-Pin CPU fan (Quiet Fan) support, the 3-Pin CPU fan still can work successfully even without the fan speed control function. If you plan to connect the 3-Pin CPU fan to the CPU fan connector on this motherboard, please connect it to Pin 1-3.

Pin 1-3 Connected ←

3-Pin Fan Installation



ATX Power Connector

(24-pin ATXPWR1)
(see p.2 No. 5)

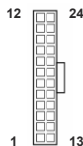

Please connect an ATX power supply to this connector.



Though this motherboard provides 24-pin ATX power connector, it can still work if you adopt a traditional 20-pin ATX power supply. To use the 20-pin ATX power supply, please plug your power supply along with Pin 1 and Pin 13.



20-Pin ATX Power Supply Installation

ATX 12V Power Connector

(4-pin ATX12V1)
(see p.2, No. 1)



Please connect an ATX 12V power supply to this connector.

Chassis Intrusion Header

(2-pin Cl1)
(see p.2, No. 23)



This motherboard supports CASE OPEN detection feature that detects if the chassis cover has been removed. This feature requires a chassis with chassis intrusion detection design.

TPM Header

(17-pin TPMS1)
(see p.2, No. 6)

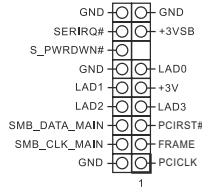

This connector supports Trusted Platform Module (TPM) system, which can securely store keys, digital certificates, passwords, and data. A TPM system also helps enhance network security, protects digital identities, and ensures platform integrity.

1. Einführung

Wir danken Ihnen für den Kauf des ASRock **FM2A88M Pro3+** Motherboard, ein zuverlässiges Produkt, welches unter den ständigen, strengen Qualitätskontrollen von ASRock gefertigt wurde. Es bietet Ihnen exzellente Leistung und robustes Design, gemäß der Verpflichtung von ASRock zu Qualität und Halbarkeit. Diese Schnellinstallationsanleitung führt in das Motherboard und die schrittweise Installation ein. Details über das Motherboard finden Sie in der Bedienungsanleitung auf der Support-CD.



Da sich Motherboard-Spezifikationen und BIOS-Software verändern können, kann der Inhalt dieses Handbuchs ebenfalls jederzeit geändert werden. Für den Fall, dass sich Änderungen an diesem Handbuch ergeben, wird eine neue Version auf der ASRock-Website, ohne weitere Ankündigung, verfügbar sein. Die neuesten Grafikkarten und unterstützten CPUs sind auch auf der ASRock-Website aufgelistet.

ASRock-Website: <http://www.asrock.com>

Wenn Sie technische Unterstützung zu Ihrem Motherboard oder spezifische Informationen zu Ihrem Modell benötigen, besuchen Sie bitte unsere Webseite:

www.asrock.com/support/index.asp

1.1 Kartoninhalt

ASRock **FM2A88M Pro3+** Motherboard (Micro ATX-Formfaktor)

ASRock **FM2A88M Pro3+** Schnellinstallationsanleitung

ASRock **FM2A88M Pro3+** Support-CD

Zwei Serial ATA (SATA) -Datenkabel (optional)

Ein I/O Shield

1.2 Spezifikationen

Plattform	<ul style="list-style-type: none"> - Micro ATX-Formfaktor - Solides Kondensatordesign - PCB mit hochverdichtetem Glasfasergewebe
CPU	<ul style="list-style-type: none"> - Unterstützt Prozessoren für Sockel FM2+ (95 W) / FM2 (100 W)
Chipsatz	<ul style="list-style-type: none"> - AMD A88X (Bolton-D4)
Speicher	<ul style="list-style-type: none"> - Unterstützung von Dual-Kanal-Speichertechnologie - 4 x Steckplätze für DDR3 - Unterstützt DDR3 2400+(OC)/2133/1866/1600/1333/1066 non-ECC, ungepufferter Speicher - Max. Kapazität des Systemspeichers: 64GB - Unterstützt Intel® Extreme Memory Profile (XMP)1.3/1.2 - Unterstützt AMDs Memory Profile Technology (AMP) bis AMP 2400
Erweiterungssteckplätze	<ul style="list-style-type: none"> - 1 x PCI Express 3.0 x16-Steckplatz (PCIe1: x6-Modus) * PCIe 3.0 wird nur mit FM2+-Prozessor unterstützt. FM2-Prozessor unterstützt nur PCIe 2.0. - 2 x PCI Express 2.0 x1-Steckplatz - Unterstützt AMD duale Grafikkarten
Onboard-VGA	<ul style="list-style-type: none"> - Integrierte Grafikkarte der AMD Radeon™ R7/R5-Serie in APU der A-Serie - DirectX 11.1, Pixel Shader 5.0 mit FM2+-Prozessor. DirectX 11, Pixel Shader 5.0 mit FM2-Prozessor. - Maximal gemeinsam genutzter Speicher 2GB - Drei VGA-Ausgangsoptionen: D-Sub, DVI-D sowie HDMI - Unterstützt drei Monitore - Unterstützt HDMI mit einer maximalen Auflösung von 4K x 2K (4096 x 2160) bei 24 Hz * Nur FM2 + APU kann bis zu 4096x2160 Auflösung Anzeige über HDMI-Anschluss unterstützt - Unterstützt Dual-link DVI-D mit einer maximalen Auflösung von 2560 x 1600 bei 60 Hz - Unterstützt D-Sub mit einer maximalen Auflösung von 1920 x 1200 bei 60 Hz - Unterstützt Auto Lip Sync, Deep Color (12bpc), xvYCC und HBR (High Bit Rate-Audio) mit HDMI (kompatibler HDMI-Bildschirm erforderlich) - Unterstützt stereoskopisches 3D per Blu-ray mit HDMI

	<ul style="list-style-type: none"> - Unterstützt AMD Steady Video™ 2.0: Neuartige Funktion der Videonachbearbeitung für automatische Reduzierung von Bildschwankungen bei Heim-/Online-Videos - Unterstützt HDCP mit DVI-D- und HDMI-Ports - Unterstützt 1080p Blu-ray (BD)-Wiedergabe mit DVI-D- und HDMI-Ports
Audio	<ul style="list-style-type: none"> - 5.1-Kanal-HD-Audio (Realtek ALC662-Audiocodec) - Unterstützt Überspannungsschutz (ASRocks Komplettschutz vor Spannungsspitzen) - ELNA Audio Caps.
LAN	<ul style="list-style-type: none"> - PCIE x1 Gigabit LAN 10/100/1000 Mb/s - Realtek RTL8111GR - Unterstützt Wake-On-WAN - Unterstützt Wake-On-LAN - Unterstützt Schutz vor Blitzschlag/elektrostatischer Entladung (ASRocks Komplettschutz vor Spannungsspitzen) - Unterstützt LAN-Kabelerkennung - Unterstützt energieeffizientes Ethernet 802.3az - Unterstützt PXE
E/A-Anschlüsse an der Rückseite	<ul style="list-style-type: none"> - 1 x PS/2-Mausanschluss - 1 x PS/2-Tastaturanschluss - 1 x D-Sub port - 1 x DVI-D port - 1 x HDMI port - 4 x Standard-USB 2.0-Anschlüsse (Unterstützt Schutz vor elektrostatischer Entladung (ASRocks Komplettschutz vor Spannungsspitzen)) - 2 x Standard-USB 3.0-Anschlüsse (AMD A88X (Bolton-D4)) (Unterstützt Schutz vor elektrostatischer Entladung (ASRocks Komplettschutz vor Spannungsspitzen)) - 1 x RJ-45 LAN Port mit LED (ACT/LINK LED und SPEED LED) - HD Audiobuchse: Audioeingang / Lautsprecher vorne / Mikrofon
Speicher	<ul style="list-style-type: none"> - 8 x SATA 3-Anschluss mit 6,0 Gb/s, unterstützt RAID- (RAID 0, RAID 1, RAID 5 und RAID 10), NCQ-, AHCI- und „Hot Plugging“-Funktionen



Anschlüsse	<ul style="list-style-type: none"> - 1 x Verteiler für Gehäuseeindringversuche - 1 x TPM-Stiftleiste - 1 x CPUlüfter-Anschluss (4-pin) - 1 x Gehäuselüfter-Anschluss (4-pin) - 1 x 24-pin ATX-Netz-Header - 1 x 4-pin anschluss für 12V-ATX-Netzteil - 1 x Anschluss für Audio auf der Gehäusevorderseite - 2 x USB 2.0-Anschlüsse (Unterstützung 4 zusätzlicher USB 2.0-Anschlüsse) (Unterstützt Schutz vor elektrostatischer Entladung (ASRocks Komplettschutz vor Spannungsspitzen)) - 1 x USB 3.0-Anschlüsse über AMD A88X (Bolton-D4) (Unterstützung 2 zusätzlicher USB 3.0-Anschlüsse) (Unterstützt Schutz vor elektrostatischer Entladung (ASRocks Komplettschutz vor Spannungsspitzen))
BIOS	<ul style="list-style-type: none"> - 64Mb AMIs Legal BIOS UEFI mit GUI-Unterstützung - Unterstützung für "Plug and Play" - ACPI 1.1-Weckfunktionen - JumperFree-Modus - SMBIOS 2.3.1 - DRAM und CPU Stromspannung Multianpassung
Hardware Monitor	<ul style="list-style-type: none"> - CPU-Temperatursensor - Motherboardtemperaturerkennung - Drehzahlmessung für CPUlüfter - Drehzahlmessung für Gehäuselüfter - Geräuscharmer CPU/Gehäuselüfter - Mehrstufige Geschwindigkeitsteuerung für CPU-/Gehäuselüfter - GEHÄUSE OFFEN-Erkennung - Spannungsüberwachung: +12V, +5V, +3.3V, Vcore
Betriebssysteme	<ul style="list-style-type: none"> - Unterstützt Microsoft® Windows® 8.1 32-Bit / 8.1 64-Bit / 8 32-Bit / 8 64-Bit / 7 32-Bit / 7 64-Bit
Zertifizierungen	<ul style="list-style-type: none"> - FCC, CE, WHQL - Gemäß Ökodesign-Richtlinie (ErP/EuP) (Stromversorgung gemäß Ökodesign-Richtlinie (ErP/EuP) erforderlich)

* Für die ausführliche Produktinformation, besuchen Sie bitte unsere Website:
<http://www.asrock.com>

1.3 Einstellung der Jumper

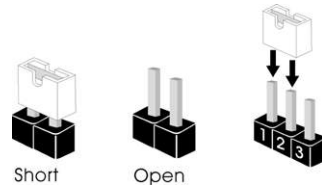
Die Abbildung verdeutlicht, wie Jumper gesetzt werden. Werden Pins durch Jumperkappen verdeckt, ist der Jumper "Gebrückt". Werden keine Pins durch Jumperkappen verdeckt, ist der Jumper "Offen". Die Abbildung zeigt einen 3-Pin Jumper dessen Pin1 und Pin2 "Gebrückt" sind, bzw. es befindet sich eine Jumper-Kappe auf diesen beiden Pins.



Jumper	Einstellung	Beschreibung
CMOS löschen (CLRCMOS1, 3-Pin jumper) (siehe S.2, No. 22)	1_2  Default-Einstellung	2_3  CMOS löschen

Hinweis: CLRCMOS1 ermöglicht Ihnen die Löschung der Daten im CMOS. Zum Löschen und Zurücksetzen der Systemparameter auf die Standardeinrichtung schalten Sie den Computer bitte aus und trennen das Netzkabel von der Stromversorgung. Warten Sie 15 Sekunden, schließen Sie dann Pin2 und Pin3 am CLRCMOS1 über einen Jumper fünf Sekunden lang kurz. Sie sollten das CMOS allerdings nicht direkt nach der BIOS-Aktualisierung löschen. Wenn Sie das CMOS nach Abschluss der BIOS-Aktualisierung löschen müssen, fahren Sie zuerst das System hoch. Fahren Sie es dann vor der CMOS-Löschung herunter. Bitte beachten Sie, dass Kennwort, Datum, Uhrzeit, benutzerdefiniertes Profil, 1394 GUID und MAC-Adresse nur gelöscht werden, wenn die CMOS-Batterie entfernt wird.



Durch Löschen des CMOS kann erkannt werden, wenn das Gehäuse offen ist. Bitte stellen Sie zum Löschen der Aufzeichnung des vorherigen Gehäuseeintrittsstatus die BIOS-Option "Status leeren" ein.

1.4 Anschlüsse



Anschlussleisten sind KEINE Jumper. Setzen Sie KEINE Jumperkappen auf die Pins der Anschlussleisten. Wenn Sie die Jumperkappen auf die Anschlüsse setzen, wird das Motherboard permanent beschädigt!

Anschluss

Beschreibung

Seriell-ATA3-Anschlüsse

- (SATA_1: siehe S.2 - No. 16)
- (SATA_2: siehe S.2 - No. 15)
- (SATA_3: siehe S.2 - No. 14)
- (SATA_4: siehe S.2 - No. 13)
- (SATA_5: siehe S.2 - No. 12)
- (SATA_6: siehe S.2 - No. 11)
- (SATA_7: siehe S.2 - No. 9)
- (SATA_8: siehe S.2 - No. 8)



Diese acht Serial ATA3- (SATA3-)Verbinder unterstützen SATA-Datenkabel für interne Massenspeichergeräte. Die aktuelle SATA3- Schnittstelle ermöglicht eine Datenübertragungsrate bis 6,0 Gb/s.

USB 2.0-Header

- (9-pol. USB_6_7)
- (siehe S.2 - No. 18)
- (9-pol. USB_8_9)
- (siehe S.2 - No. 19)

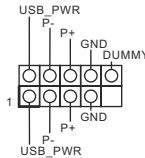

Zusätzlich zu den vier üblichen USB 2.0-Ports an den I/O-Anschlüssen befinden sich zwei USB 2.0-Anschlussleisten am Motherboard. Pro USB 2.0-Anschlussleiste werden zwei USB 2.0-Ports unterstützt.

USB 3.0-Header

- (19-pol. USB_10_11)
- (siehe S.2 - No. 20)

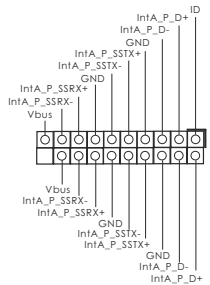

Neben zwei Standard-USB 3.0-Ports am E/A-Panel befindet sich ein USB 3.0-Header an diesem Motherboard. Dieser USB 3.0-Header kann zwei USB 3.0-Ports unterstützen.

Anschluss für Audio auf der Gehäusevorderseite

(9-Pin HD_AUDIO1)

(siehe S.2 - No. 21)

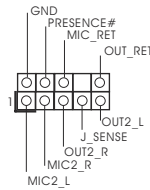

Dieses Interface zu einem Audio-Panel auf der Vorderseite Ihres Gehäuses, ermöglicht Ihnen eine bequeme Anschlussmöglichkeit und Kontrolle über Audio-Geräte.



1. High Definition Audio unterstützt Jack Sensing (automatische Erkennung falsch angeschlossener Geräte), wobei jedoch die Bildschirmverdrahtung am Gehäuse HDA unterstützen muss, um richtig zu funktionieren. Beachten Sie bei der Installation im System die Anweisungen in unserem Handbuch und im Gehäusehandbuch.
2. Wenn Sie die AC'97-Audioleiste verwenden, installieren Sie diese wie nachstehend beschrieben an der Front-Audioanschlussleiste:
 - A. Schließen Sie Mic_IN (MIC) an MIC2_L an.
 - B. Schließen Sie Audio_R (RIN) an OUT2_R und Audio_L (LIN) an OUT2_L an.
 - C. Schließen Sie Ground (GND) an Ground (GND) an.
 - D. MIC_RET und OUT_RET sind nur für den HD-Audioanschluss gedacht. Diese Anschlüsse müssen nicht an die AC'97-Audioleiste angeschlossen werden.
 - E. So aktivieren Sie das Mikrofon an der Vorderseite.
Bei den Betriebssystemen Windows® 8.1 / 8.1 64 Bit / 8 / 8 64 Bit / 7 / 7 64 Bit: Wählen Sie im Realtek-Bedienfeld die „FrontMic“ (Vorderes Mikrofon)-Registerkarte. Passen Sie die „Recording Volume“ (Aufnahmelautstärke) an.

System Panel-Header

(9-pin PANEL1)

(siehe S.2 - No. 17)

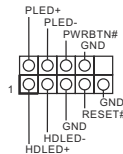

Dieser Header unterstützt mehrere Funktion der Systemvorderseite.



Schließen Sie die Ein-/Austaste, die Reset-Taste und die Systemstatusanzeige am Gehäuse an diesen Header an; befolgen Sie dabei die nachstehenden Hinweise zur Pinbelegung. Beachten Sie die positiven und negativen Pins, bevor Sie die Kabel anschließen.

PWRBTN (Ein-/Ausschalter):

Zum Anschließen des Ein-/Ausschalters an der Frontblende des Gehäuses. Sie können konfigurieren, wie das System mit Hilfe des Ein-/Ausschalters ausgeschaltet werden können soll.

RESET (Reset-Taste):

Zum Anschließen der Reset-Taste an der Frontblende des Gehäuses. Mit der Reset-Taste können Sie den Computer im Falle eines Absturzes neu starten.

PLED (Systembetriebs-LED):

Zum Anschließen der Betriebsstatusanzeige an der Frontblende des Gehäuses. Die LED leuchtet, wenn das System in Betrieb ist. Die LED blinkt, wenn sich das System im Ruhezustand S1 befindet. Die LED schaltet sich aus, wenn sich das System in den Modi S3/S4 befindet oder ausgeschaltet ist (S5).

HDLED (Festplattenaktivitäts-LED):

Zum Anschließen der Festplattenaktivitäts-LED an der Frontblende des Gehäuses. Die LED leuchtet, wenn die Festplatte Daten liest oder schreibt.

Das Design der Frontblende kann je nach Gehäuse variieren. Ein Frontblendenmodul besteht hauptsächlich aus einer Ein-/Austaste, einer Reset-Taste, einer Betriebs-LED, einer Festplattenaktivitäts-LED, Lautsprechern, etc. Stellen Sie beim Anschließen des Frontblendenmoduls Ihres Gehäuses an diesem Header sicher, dass die Kabel- und Pinbelegung korrekt übereinstimmen.

Gehäuselautsprecher-Header

(4-pin SPEAKER1)
(siehe S.2 - No. 7)

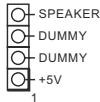

Schließen Sie den Gehäuselautsprecher an diesen Header an.

Gehäuse-Lüfteranschluss

(4-pin CHA_FAN1)
(siehe S.2, No. 10)

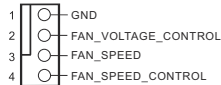

Verbinden Sie die Lüfterkabel mit den Lüfteranschlüssen, wobei der schwarze Draht an den Schutzleiterstift angeschlossen wird.

CPU-Lüfteranschluss

(4-pin CPU_FAN1)
(siehe S.2 - No. 2)

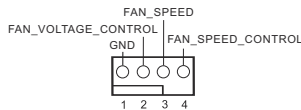

Verbinden Sie das CPU - Lüfterkabel mit diesem Anschluss und passen Sie den schwarzen Draht dem Erdungsstift an.



Obwohl dieses Motherboard einen vierpoligen CPU-Lüfteranschluss (Quiet Fan) bietet, können auch CPU-Lüfter mit dreipoligem Anschluss angeschlossen werden; auch ohne Geschwindigkeitsregulierung. Wenn Sie einen dreipoligen CPU-Lüfter an den CPU-Lüfteranschluss dieses Motherboards anschließen möchten, verbinden Sie ihn bitte mit den Pins 1 – 3.

Pins 1–3 anschließen ←

Lüfter mit dreipoligem Anschluss installieren



ATX-Netz-Header

(24-pin ATXPWR1)

(siehe S.2 - No. 5)

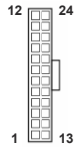

Verbinden Sie die ATX-Stromversorgung mit diesem Header.



Obwohl dieses Motherboard einen 24-pol. ATX-Stromanschluss bietet, kann es auch mit einem modifizierten traditionellen 20-pol. ATX-Netzteil verwendet werden. Um ein 20-pol. ATX-Netzteil zu verwenden, stecken Sie den Stecker mit Pin 1 und Pin 13 ein.

Installation eines 20-pol. ATX-Netzteils

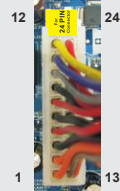

ATX 12V Anschluss

(4-pin ATX12V1)

(siehe S.2 - No. 1)



Bitte schließen Sie an diesen Anschluss die ATX 12V Stromversorgung an.

Verteiler für Gehäuseeindringversuche

(2-pin C11)

(siehe S.2 - No. 23)



Dieses Motherboard unterstützt die GEHÄUSE OFFEN-Erkennungsfunktion, die feststellt, ob die Gehäuseabdeckung entfernt wurde. Für diese Funktion ist ein Gehäuse erforderlich, das mit einem Design zur Erkennung von Gehäuseeindringversuchen ausgestattet ist.

TPM-Stiftleiste

(17-pol. TPMS1)

(siehe S.2 - No. 6)

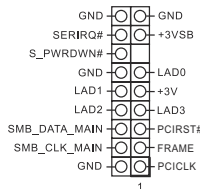

Dieser Anschluss unterstützt das Trusted Platform Module (TPM) System, das Schlüssel, digitale Zertifikate, Kennwörter und Daten sicher aufbewahren kann. Ein TPM-System hilft zudem bei der Stärkung der Netzwerksicherheit, schützt digitale Identitäten und gewährleistet die Plattformintegrität.

1. Introduction

Merci pour votre achat d'une carte mère ASRock **FM2A88M Pro3+**, une carte mère très fiable produite selon les critères de qualité rigoureux de ASRock. Elle offre des performances excellentes et une conception robuste conformément à l'engagement d'ASRock sur la qualité et la fiabilité au long terme.

Ce Guide d'installation rapide présente la carte mère et constitue un guide d'installation pas à pas. Des informations plus détaillées concernant la carte mère pourront être trouvées dans le manuel l'utilisateur qui se trouve sur le CD d'assistance.



Les spécifications de la carte mère et le BIOS ayant pu être mis à jour, le contenu de ce manuel est sujet à des changements sans notification. Au cas où n'importe quelle modification intervenait sur ce manuel, la version mise à jour serait disponible sur le site web ASRock sans nouvel avis. Vous trouverez les listes de prise en charge des cartes VGA et CPU également sur le site Web ASRock. Site web ASRock, <http://www.asrock.com>
Si vous avez besoin de support technique en relation avec cette carte mère, veuillez consulter notre site Web pour de plus amples informations particulières au modèle que vous utilisez.
www.asrock.com/support/index.asp

1.1 Contenu du paquet

Carte mère ASRock **FM2A88M Pro3+** (Facteur de forme Micro ATX)

Guide d'installation rapide ASRock **FM2A88M Pro3+**

CD de soutien ASRock **FM2A88M Pro3+**

Deux câbles de données de série ATA (SATA) (en option)

Un I/O Panel Shield

1.2 Spécifications

Format	<ul style="list-style-type: none"> - Facteur de forme Micro ATX - Conception à condensateurs solides - PCB High Density Glass Fabric
CPU	<ul style="list-style-type: none"> - Prend en charge les processeurs à socket FM2+ 95W / FM2 100W
Chipsets	<ul style="list-style-type: none"> - AMD A88X (Bolton-D4)
Mémoire	<ul style="list-style-type: none"> - Compatible avec la Technologie de Mémoire à Canal Double - 4 x slots DIMM DDR3 - Supporter DDR3 2400+(OC)/2133/1866/1600/1333/1066 non-ECC, sans amortissement mémoire - Capacité maxi de mémoire système: 64GB - Prend en charge le profil de mémoire extrême Intel® (XMP) 1.3/1.2 - Prend en charge la technologie AMD Memory Profile (Profil de mémoire AMD - AMP) jusqu'à AMP 2400
Slot d'extension	<ul style="list-style-type: none"> - 1 x slot PCI Express 3.0 x16 (PCIE1 à mode x16) * PCIE 3.0 est uniquement pris en charge le processeur FM2+. Avec le processeur FM2, seul PCIE 2.0 est pris en charge. - 2 x slot PCI Express 2.0 x1 - Support de AMD Dual Graphics
VGA sur carte	<ul style="list-style-type: none"> - APU AMD Radeon™ R7/R5 série graphiques A-series - DirectX 11.1, Pixel Shader 5.0 avec processeur FM2+. - DirectX 11, Pixel Shader 5.0 avec processeur FM2. - mémoire partagée max 2GB - Trois options de sortie VGA: D-Sub, DVI-D et HDMI - Prend en charge la configuration à triple moniteurs - Prend en charge le HDMI avec une résolution maximale jusqu'à 4K x 2K (4096x2160) @ 24Hz * Seuls les APUs FM2+ acceptent une résolution jusqu'à 4096x2160 via le port HDMI. - Prend en charge le Dual-link DVI-D avec une résolution maximale jusqu'à 2560x1600 @ 60Hz - Prend en charge le D-Sub avec une résolution maximale jusqu'à 1920x1600 @ 60Hz - Prend en charge Lip Sync, Deep Color (12bpc), xvYCC et HBR (High Bit Rate Audio: Audio à haut débit binaire) avec HDMI (Moniteur compatible HDMI requis)

	<ul style="list-style-type: none"> - Prend en charge la 3D stéréoscopique Blu-ray avec HDMI - Supporte AMD Steady Video™ 2.0: Nouvelle fonctionnalité de traitement post-vidéo pour réduction automatique des tremblements dans les clips vidéo en ligne/maison - Prise en charge de la fonction HDCP avec ports DVI-D et HDMI - Supporter 1080p Blu-ray(BD) avec ports DVI-D et HDMI
Audio	<ul style="list-style-type: none"> - Audio 5.1 CH HD (codec audio Realtek ALC662) - Supporte la protection contre les surtensions (protection complète contre surges ASRock) - ELNA Audio Caps.
LAN	<ul style="list-style-type: none"> - PCIE x1 Gigabit LAN 10/100/1000 Mo/s - Realtek RTL8111GR - Supporte le réveil-sur-WAN - Prend en charge la fonction Wake-On-LAN - Supporte la protection contre la foudre/ESD (protection complète contre surges ASRock) - Prise en charge de la détection de câble LAN - Prend en charge la fonction d'économie d'énergie Ethernet 802.3az - Prend en charge PXE
Panneau arrière	<ul style="list-style-type: none"> - 1 x port souris PS/2 - 1 x port clavier PS/2 - 1 x port D-Sub - 1 x port DVI-D - 1 x port HDMI - 4 x ports USB 2.0 par défaut ((Supporte la protection ESD (protection complète contre surges ASRock)) - 2 x ports USB 3.0 par défaut (AMD A88X (Bolton-D4)) ((Supporte la protection ESD (protection complète contre surges ASRock)) - 1 x port LAN RJ-45 avec LED (ACT/LED CLIGNOTANTE et LED VITESSE) - Prise HD Audio: Entrée Ligne / Haut-parleur frontal / Microphone
Stockage	<ul style="list-style-type: none"> - 8 x connecteurs 6,0 Gb/s SATA3, prise en charge des fonctions RAID (RAID 0, RAID 1, RAID 5 et RAID 10), NCQ, AHCI et « Connexion à chaud »

Connecteurs	<ul style="list-style-type: none"> - 1 x Embase d'intrusion châssis - 1 x embase TPM - 1 x Connecteur pour ventilateur de CPU (br. 4) - 1 x Connecteur pour ventilateur de Châssis (br. 4) - 1 x br. 24 connecteur d'alimentation ATX - 1 x br. 4 connecteur d'alimentation 12V ATX - 1 x Connecteur audio panneau avant - 2 x En-tête USB 2.0 (prendre en charge 4 ports USB 2.0 supplémentaires) ((Supporte la protection ESD (protection complète contre surges ASRock)) - 1 x En-tête USB 3.0 de AMD A88X (Bolton-D4) (prendre en charge 2 ports USB 3.0 supplémentaires) ((Supporte la protection ESD (protection complète contre surges ASRock))
BIOS	<ul style="list-style-type: none"> - 64Mb AMI UEFI Legal BIOS avec support GUI - Support du "Plug and Play" - Compatible pour événements de réveil ACPI 1.1 - Gestion jumperless - Support SMBIOS 2.3.1 - DRAM et CPU Tension Multi-ajustement
Surveillance système	<ul style="list-style-type: none"> - Détection de la température du processeur - Détection de la température du châssis - Tachéomètre du ventilateur processeur - Tachéomètre du ventilateur châssis - Fonction ventilateur silencieux processeur/châssis Quiet Fan - Contrôle simultané des vitesse du ventilateur processeur/ châssis - Détection d'OUVERTURE DE BOÎTIER - Monitoring de la tension: +12V, +5V, +3.3V, Vcore
OS	<ul style="list-style-type: none"> - Microsoft® Windows® 8.1 32-bit / 8.1 64-bit / 8 32-bit / 8 64-bit / 7 32-bit / 7 64-bit
Certifications	<ul style="list-style-type: none"> - FCC, CE, WHQL - Prêt pour ErP/EuP (alimentation Prêt pour ErP/EuP requise)

* Pour de plus amples informations sur les produits, s'il vous plaît visitez notre site web:

<http://www.asrock.com>

1.3 Réglage des cavaliers

L'illustration explique le réglage des cavaliers. Quand un capuchon est placé sur les broches, le cavalier est « FERME ». Si aucun capuchon ne relie les broches, le cavalier est « OUVERT ». L'illustration montre un cavalier à 3 broches dont les broches 1 et 2 sont « FERMEES » quand le capuchon est placé sur ces 2 broches.

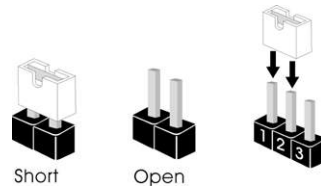

Le cavalier

Description

Effacer la CMOS
(CLRCMOS1)
(voir p.2 fig. 22)

1 2

Paramètres
par défaut

2 3

Effacer la
CMOS

Remarque : CLRCMOS1 vous permet d'effacer les données du CMOS. Pour effacer et réinitialiser les paramètres du système à la configuration originale, veuillez éteindre l'ordinateur et débrancher le cordon d'alimentation de la prise de courant. Après 15 secondes, utilisez un couvercle de jumper pour court-circuiter les broches pin2 et pin3 de CLRCMOS1 pendant 5 secondes. Veuillez cependant ne pas effacer le CMOS immédiatement après avoir mis à jour le BIOS. Si vous avez besoin d'effacer le CMOS après avoir mis à jour le BIOS, vous devez allumer en premier le système, puis l'éteindre avant de continuer avec l'opération d'effacement du CMOS. Veuillez noter que le mot de passe, la date, l'heure, le profil par défaut de l'utilisateur, 1394 GUID et l'adresse MAC seront effacés seulement si la batterie du CMOS est enlevée.



Si vous effacez la CMOS, il se peut qu'une ouverture du boîtier soit détectée. Veuillez ajuster l'option du BIOS "Clear Status" (Effacer l'état) pour effacer la mention d'état d'intrusion dans le châssis.

1.4 En-têtes et Connecteurs sur Carte



Les en-têtes et connecteurs sur carte NE SONT PAS des cavaliers. NE PAS placer les capuchons de cavalier sur ces en-têtes et connecteurs. Le fait de placer les capuchons de cavalier sur les en-têtes et connecteurs causera à la carte mère des dommages irréversibles!

Connecteurs Série ATA3

- (SATA_1: voir p.2 No. 16)
- (SATA_2: voir p.2 No. 15)
- (SATA_3: voir p.2 No. 14)
- (SATA_4: voir p.2 No. 13)
- (SATA_5: voir p.2 No. 12)
- (SATA_6: voir p.2 No. 11)
- (SATA_7: voir p.2 No. 9)
- (SATA_8: voir p.2 No. 8)



Ces huit connecteurs Série ATA3 (SATA3) prennent en charge les câbles SATA pour les périphériques de stockage internes. L'interface SATA3 actuelle permet des taux transferts de données pouvant aller jusqu'à 6,0 Gb/s.



En-tête USB 2.0

- (USB_6_7 br.9)
- (voir p.2 No. 18)
- (USB_8_9 br.9)
- (voir p.2 No. 19)

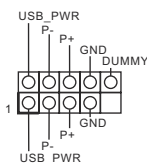

A côté des quatre ports USB 2.0 par défaut sur le panneau E/S, il y a deux embases USB 2.0 sur cette carte mère. Chaque embase USB 2.0 peut prendre en charge 2 ports USB 2.0.

En-tête USB 3.0

- (USB_10_11 br. 19)
- (voir p.2 No. 20)

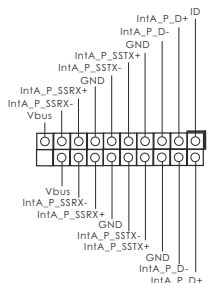

En plus des deux ports USB 3.0 par défaut sur le panneau E/S, il y a une barrette USB 3.0 sur la carte mère. Cette barrette USB 3.0 peut prendre en charge deux ports USB 3.0.

Connecteur audio panneau

(HD_AUDIO1 br. 9)

(voir p.2 No. 21)

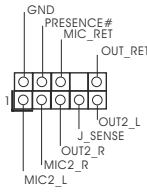

C'est une interface pour un câble avant audio en façade qui permet le branchement et le contrôle commodes de périphériques audio.



1. L'audio à haute définition (HDA) prend en charge la détection de fiche, mais le fil de panneau sur le châssis doit prendre en charge le HDA pour fonctionner correctement. Veuillez suivre les instructions dans notre manuel et le manuel de châssis afin d'installer votre système.
2. Si vous utilisez le panneau audio AC'97, installez-le sur l'adaptateur audio du panneau avant conformément à la procédure ci-dessous :
 - A. Connectez Mic_IN (MIC) à MIC2_L.
 - B. Connectez Audio_R (RIN) à OUT2_R et Audio_L (LIN) à OUT2_L.
 - C. Connectez Ground (GND) à Ground (GND).
 - D. MIC_RET et OUT_RET sont réservés au panneau audio HD. Vous n'avez pas besoin de les connecter pour le panneau audio AC'97.
 - E. Pour activer le micro avant.

Pour les systèmes d'exploitation Windows® 8.1 / 8.1 64 bits / 8 / 8 64 bits / 7 / 7 64 bits:

Allez sur l'onglet "FrontMic" (Micro avant) sur le Panneau de contrôle Realtek. Ajustez "Recording Volume" (Volume d'enregistrement).

En-tête du panneau système

(PANEL1 br.9)

(voir p.2 No. 17)

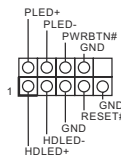

Cet en-tête permet d'utiliser plusieurs fonctions du panneau système frontal.



Connectez l'interrupteur d'alimentation, l'interrupteur de réinitialisation et l'indicateur d'état du système du châssis sur cette barrette en respectant l'affectation des broches décrite ci-dessous. Faites attention aux broches positives et négatives avant de connecter les câbles.

PWRBTN (Interrupteur d'alimentation):

Connectez ici le connecteur d'alimentation sur le panneau avant du châssis. Vous pouvez configurer la façon de mettre votre système hors tension avec l'interrupteur d'alimentation.

RESET (Interrupteur de réinitialisation):

Connectez ici le connecteur de réinitialisation sur le panneau avant du châssis. Appuyez sur l'interrupteur de réinitialisation pour redémarrer l'ordinateur s'il se bloque ou s'il n'arrive pas à redémarrer normalement.

PLED (DEL alimentation système):

Connectez ici l'indicateur d'état de l'alimentation sur le panneau avant du châssis. Ce voyant DEL est allumé lorsque le système est en marche. Le voyant DEL clignote lorsque le système est en mode veille S1. Le voyant DEL est éteint lorsque le système est en mode veille S3/S4 ou lorsqu'il est éteint (S5).

HDLED (DEL activité du disque dur):

Connectez ici le voyant DEL d'activité du disque dur sur le panneau avant du châssis. Ce voyant DEL est allumé lorsque le disque dur est en train de lire ou d'écrire des données.

Le design du panneau avant peut varier en fonction du châssis. Un module de panneau avant consiste principalement en : interrupteur d'alimentation, interrupteur de réinitialisation, voyant DEL d'alimentation, voyant DEL d'activité du disque dur, haut-parleur, etc. Lorsque vous connectez le panneau avant de votre châssis sur cette barrette, vérifiez bien à faire correspondre les fils et les broches.

En-tête du haut-parleur de châssis

(SPEAKER1 br. 4)
(voir p.2 No. 7)

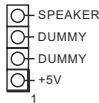

Veillez connecter le haut-parleur de châssis sur cet en-tête.

Connecteur du ventilateur de châssis

(CHA_FAN1 br. 4)
(voir p.2 No. 10)

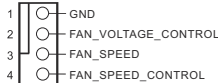

Branchez les câbles du ventilateur aux connecteurs pour ventilateur et faites correspondre le fil noir à la broche de terre.

Connecteur du ventilateur de l'UC

(CPU_FAN1 br. 4)
(voir p.2 No. 2)

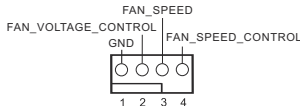

Veillez connecter le câble de ventilateur d'UC sur ce connecteur et brancher le fil noir sur la broche de terre.



Bien que cette carte mère offre un support de (Ventilateur silencieux ventilateur de CPU à 4 broches , le ventilateur de CPU à 3 broches peut bien fonctionner même sans la fonction de commande de vitesse du ventilateur. Si vous prévoyez de connecter le ventilateur de CPU à 3 broches au connecteur du ventilateur de CPU sur cette carte mère, veuillez le connecter aux broches 1-3.

Installation de ventilateur à 3 broches ←

Broches 1-3 connectées



En-tête d'alimentation ATX

(ATXPWR1 br. 24)

(voir p.2 No. 5)

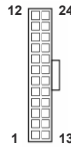

Veuillez connecter l'unité d'alimentation ATX sur cet en-tête.



Bien que cette carte mère fournisse un connecteur de courant ATX 24 broches, elle peut encore fonctionner si vous adopter une alimentation traditionnelle ATX 20 broches. Pour utiliser une alimentation ATX 20 broches, branchez à l'alimentation électrique ainsi qu'aux broches 1 et 13.

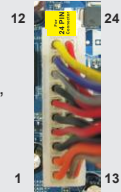

20-Installation de l'alimentation électrique ATX

Connecteur ATX 12V

(ATX12V1 br.4)

(voir p.2 No. 1)



Veuillez connecter une unité d'alimentation électrique ATX 12V sur ce connecteur.

Embase d'intrusion châssis

(CI1 br.2)

(voir p.2 No. 23)



Cette carte-mère prend en charge la détection d'OUVERTURE DE BOÎTIER, qui détecte tout retrait du capot du châssis. Cette fonction nécessite un châssis qui a été conçu pour la détection d'intrusion dans le châssis.

Embase TPM

(TPMS1 17 broches)

(voir p.2 No. 6)

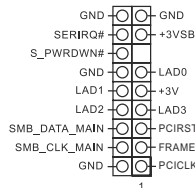

Ce connecteur prend en charge un module TPM (Trusted Platform Module – Module de plateforme sécurisée), qui permet de sauvegarder clés, certificats numériques, mots de passe et données en toute sécurité. Le système TPM permet également de renforcer la sécurité du réseau, de protéger les identités numériques et de préserver l'intégrité de la plateforme.

1. Introduzione

Grazie per aver scelto una scheda madre ASRock **FM2A88M Pro3+**, una scheda madre affidabile prodotta secondo i severi criteri di qualità ASRock. Le prestazioni eccellenti e il design robusto si conformano all'impegno di ASRock nella ricerca della qualità e della resistenza.

Questa Guida Rapida all'Installazione contiene l'introduzione alla motherboard e la guida passo-passo all'installazione. Informazioni più dettagliate sulla motherboard si possono trovare nel manuale per l'utente presente nel CD di supporto.



Le specifiche della scheda madre e il software del BIOS possono essere aggiornati, pertanto il contenuto di questo manuale può subire variazioni senza preavviso. Nel caso in cui questo manuale sia modificato, la versione aggiornata sarà disponibile sul sito di ASRock senza altro avviso. Sul sito ASRock si possono anche trovare le più recenti schede VGA e gli elenchi di CPU supportate.

ASRock website <http://www.asrock.com>

Se si necessita dell'assistenza tecnica per questa scheda madre, visitare il nostro sito per informazioni specifiche sul modello che si sta usando.

www.asrock.com/support/index.asp

1.1 Contenuto della confezione

Scheda madre ASRock **FM2A88M Pro3+** (Micro ATX Form Factor)

Guida di installazione rapida ASRock **FM2A88M Pro3+**

CD di supporto ASRock **FM2A88M Pro3+**

Due cavi dati Serial ATA (SATA) (opzionali)

Un I/O Shield

1.2 Specifiche

Piattaforma	<ul style="list-style-type: none"> - Micro ATX Form Factor - Design di condensatore solido - Circuito in vetro ad alta densità
Processore	- Supporto per processori socket FM2+ 95W / FM2 100W
Chipset	- AMD A88X (Bolton-D4)
Memoria	<ul style="list-style-type: none"> - Supporto tecnologia Dual Channel Memory - 4 x slot DDR3 DIMM - Supporto DDR3 2400+(OC)/2133/1866/1600/1333/1066 non-ECC, memoria senza buffer - Capacità massima della memoria di sistema: 64GB - Supporto di Intel® XMP (Extreme Memory Profile) 1.3/1.2 - Supporta tecnologia AMD Memory Profile (AMP) fino ad AMP 2400
Slot di espansione	<ul style="list-style-type: none"> - 1 x slot PCI Express 3.0 x16 (PCIE1: modalità x16) * PCIE 3.0 è supportato solo con CPU FM2+. Con CPU FM2, supporta solo PCIE 2.0. - 2 x slot PCI Express 2.0 x1 - Supporta AMD Dual Graphics
VGA su scheda	<ul style="list-style-type: none"> - Grafica serie AMD Radeon™ R7/R5 integrata in APU serie A - DirectX 11.1, Pixel Shader 5.0 con CPU FM2+. DirectX 11, Pixel Shader 5.0 con CPU FM2. - Memoria massima condivisa 2GB - Tre opzioni d'output VGA: D-Sub, DVI-D e HDMI - Supporta il triplo monitor - Supporta HDMI con risoluzione massima fino a 4K x 2K (4096x2160) @ 24Hz * Solo FM2 + APU può supportare la risoluzione fino a 4096x2160 del display tramite la porta HDMI. - Supporta Dual-link DVI-D con risoluzione massima fino a 2560x1600 @ 60Hz - Supporta D-Sub con risoluzione massima fino a 1920x1200 @ 60Hz - Supporto delle funzioni Auto Lip Sync, Deep Color (12bpc), xvYCC e HBR (High Bit Rate Audio) con HDMI (è necessario un monitor compatibile HDMI) - Supporta Blu-ray Stereoscopico in 3D con HDMI - Supporta AMD Steady Video™ 2.0: Nuova capacità di post-elab orazione video per la riduzione automatica delle vibrazioni nei video a casa/on-line

	<ul style="list-style-type: none"> - Supporto della funzione HDCP con le porte DVI-D e HDMI - Supporto 1080p Blu-ray (BD) riproduzione con le porte DVI-D e HDMI
Audio	<ul style="list-style-type: none"> - Audio HD a 5.1 canali (codec audio Realtek ALC662) - Supporto protezione da sovratensione (protezione completa ASRock dai picchi di corrente) - ELNA Audio Caps.
LAN	<ul style="list-style-type: none"> - PCIE x 1 LAN Gigabit 10/100/1000 Mb/s - Realtek RTL8111GR - Supporto WOW (Wake-On-WAN) - Supporta Wake-On-LAN - Supporto la protezione da fulmini/scariche elettrostatiche (ESD) (protezione completa ASRock dai picchi di corrente) - Supporta il rilevamento cavo LAN - Supporta Energy Efficient Ethernet 802.3az - Supporta PXE
Pannello posteriore I/O	<ul style="list-style-type: none"> - 1 x porta mouse PS/2 - 1 x porta tastiera PS/2 - 1 x Porta D-Sub - 1 x Porta DVI-D - 1 x Porta HDMI - 4 x porte USB 2.0 già integrate (Supporto della protezione da scariche elettrostatiche (ESD) (protezione completa ASRock dai picchi di corrente)) - 2 x porte USB 3.0 già integrate (AMD A88X (Bolton-D4)) (Supporto della protezione da scariche elettrostatiche (ESD) (protezione completa ASRock dai picchi di corrente)) - 1 x porte LAN RJ-45 con LED (LED azione/collegamento e LED velocità) - Connettore HD Audio: Ingresso linea / cassa frontale / microfono
Archiviazione	<ul style="list-style-type: none"> - 8 x connettori SATA3 6,0 Gb/s, supporto di RAID (RAID 0, RAID 1, RAID 5 e RAID 10) e delle funzioni NCQ, AHCI e "Hot Plug"
Connettori	<ul style="list-style-type: none"> - 1 x header di intrusione dello chassis - 1 x header TPM - 1 x Connettore CPU ventola (4-pin) - 1 x Connettore Chassis ventola (4-pin) - 1 x 24-pin collettore alimentazione ATX - 1 x 4-pin connettore ATX 12V - 1 x Connettore audio sul pannello frontale

	<ul style="list-style-type: none"> - 2 x Collettore USB 2.0 (supporta 4 porte USB 2.0) (Supporto della protezione da scariche elettrostatiche (ESD) (protezione completa ASRock dai picchi di corrente)) - 1 x Collettore USB 3.0 di AMD A88X (Bolton-D4) (supporta 2 porte USB 3.0) (Supporto della protezione da scariche elettrostatiche (ESD) (protezione completa ASRock dai picchi di corrente))
BIOS	<ul style="list-style-type: none"> - 64Mb AMI UEFI Legal BIOS con interfaccia di supporto - Supporta "Plug and Play" - Compatibile con ACPI 1.1 wake up events - Supporta jumperfree - Supporta SMBIOS 2.3.1 - Regolazione multi-voltaggio DRAM e CPU
Monitoraggio Hardware	<ul style="list-style-type: none"> - Sensore per la temperatura del processore - Sensore temperatura scheda madre - Indicatore di velocità per la ventola del CPU - Indicatore di velocità per la ventola del Chassis - Ventola CPU/chassis silenziosa - Ventola CPU/chassis con controllo di varie velocità - Rilevamento CASE APERTO - Voltaggio: +12V, +5V, +3.3V, Vcore
Compatibilità SO	<ul style="list-style-type: none"> - Microsoft® Windows® 8.1 32 bit / 8.1 64 bit / 8 32 bit / 8 64 bit / 7 32 bit / 7 64 bit
Certificazioni	<ul style="list-style-type: none"> - FCC, CE, WHQL - Predisposto ErP/EuP (è necessaria l'alimentazione predisposta per il sistema ErP/EuP)

* Per ulteriori informazioni, prego visitare il nostro sito internet: <http://www.asrock.com>

1.3 Setup dei Jumpers

L'illustrazione mostra come sono settati i jumper. Quando il ponticello è posizionato sui pin, il jumper è "CORTOCIRCUITATO". Se sui pin non ci sono ponticelli, il jumper è "APERTO". L'illustrazione mostra un jumper a 3 pin in cui il pin1 e il pin2 sono "CORTOCIRCUITATI" quando il ponticello è posizionato su questi pin.

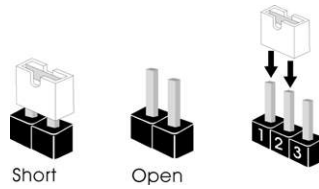

Jumper Settaggio del Jumper

Resettare la CMOS

(CLRCMOS1)
(vedi p.2 item 22)

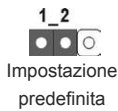

Nota: CLRCMOS1 permette di azzerare i dati nella CMOS. Per cancellare e ripristinare i parametri del sistema sulla configurazione iniziale, spegnere il computer e scollegare il cavo d'alimentazione dalla presa di corrente. Attendere 15 secondi, poi usare un cappuccio jumper per cortocircuitare il pin 2 ed il pin 3 su CLRCMOS1 per 5 secondi. Tuttavia, si consiglia di non cancellare la CMOS subito dopo avere aggiornato il BIOS. Se si deve azzerare la CMOS quando si è completato l'aggiornamento del BIOS, è necessario per prima cosa avviare il sistema e poi spegnerlo prima di eseguire l'azzeramento della CMOS. Notare che password, data, ore, profilo utente predefinito, GUID e indirizzo MAC saranno cancellati solo se è rimossa la batteria della CMOS.



Se si cancella la CMOS, potrebbe essere rilevata l'apertura del case. Regolare l'opzione del BIOS "Clear Status" (Cancella stato) per cancellare la registrazione del precedente stato d'intrusione chassis.

1.4 Collettori e Connettori su Scheda



I collettori ed i connettori su scheda NON sono dei jumper. NON installare cappucci per jumper su questi collettori e connettori. L'installazione di cappucci per jumper su questi collettori e connettori provocherà danni permanenti alla scheda madre!

Connettori Serial ATA3

- (SATA_1: vedi p.2 Nr. 16)
- (SATA_2: vedi p.2 Nr. 15)
- (SATA_3: vedi p.2 Nr. 14)
- (SATA_4: vedi p.2 Nr. 13)
- (SATA_5: vedi p.2 Nr. 12)
- (SATA_6: vedi p.2 Nr. 11)
- (SATA_7: vedi p.2 Nr. 9)
- (SATA_8: vedi p.2 Nr. 8)



Questi otto connettori Serial ATA3 (SATA3) supportano cavi dati SATA per dispositivi di immagazzinamento interni. SATA3 (SATA3) supportano cavi SATA per dispositivi di memoria interni. L'interfaccia SATA3 attuale permette velocità di trasferimento dati fino a 6.0 Gb/s.

Collettore USB 2.0

- (9-pin USB_6_7)
- (vedi p.2 Nr. 18)
- (9-pin USB_8_9)
- (vedi p.2 Nr. 19)

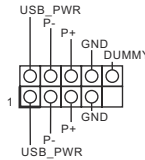

Oltre alle quattro porte USB 2.0 predefinite nel pannello I/O, la scheda madre dispone di due intestazioni USB 2.0. Ciascuna intestazione USB 2.0 supporta due porte USB 2.0.

Collettore USB 3.0

- (19-pin USB_10_11)
- (vedi p.2 Nr. 20)

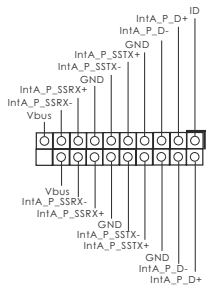

Oltre alle due porte USB 3.0 standard del pannello I/O, questa scheda madre è dotata di un header USB 3.0 che supporta due porte USB 3.0.

Italiano

Connettore audio sul pannello frontale

(9-pin HD_AUDIO1)

(vedi p.2 Nr. 21)

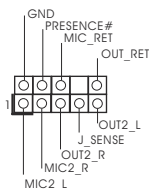

È un'interfaccia per il cavo del pannello audio. Che consente connessione facile e controllo dei dispositivi audio.



1. La caratteristica HDA (High Definition Audio) supporta il rilevamento dei connettori, però il pannello dei cavi sul telaio deve supportare la funzione HDA (High Definition Audio) per far sì che questa operi in modo corretto. Attenersi alle istruzioni del nostro manuale e del manuale del telaio per installare il sistema.
2. Se si utilizza un pannello audio AC'97, installarlo nell'intestazione audio del pannello anteriore, come indicato di seguito:
 - A. Collegare Mic_IN (MIC) a MIC2_L.
 - B. Collegare Audio_R (RIN) a OUT2_R e Audio_L (LIN) ad OUT2_L.
 - C. Collegare Ground (GND) a Ground (GND).
 - D. MIC_RET e OUT_RET sono solo per il pannello audio HD. Non è necessario collegarli per il pannello audio AC'97.
 - E. Per attivare il microfono frontale.
Sistema operativo Windows® 8.1 / 8.1 64-bit / 8 / 8 64-bit / 7 / 7 64-bit:
Andare alla scheda "FrontMic" (Microfono frontale) del pannello di controllo Realtek. Regolare la voce "Recording Volume" (Volume registrazione).

Collettore pannello di sistema

(9-pin PANEL1)

(vedi p.2 Nr. 17)

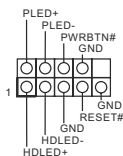

Questo collettore accomoda diverse funzioni di sistema pannello frontale.



Collegare l'interruttore d'alimentazione, l'interruttore di ripristino, l'indicatore di stato del sistema del pannello frontale del telaio a questo header in base all'assegnazione dei pin definita di seguito. Determinare i pin positivi e negativi prima di collegare i cavi.

PWRBTN (interruttore d'alimentazione):

Va collegato all'interruttore d'alimentazione del pannello frontale del telaio. Usando l'interruttore d'alimentazione si può configurare il modo in cui si spegne il sistema.

RESET (interruttore di ripristino):

Va collegato all'interruttore di ripristino del pannello frontale del telaio. Premere l'interruttore di ripristino per riavviare il sistema se il computer si blocca e non riesce ad eseguire un normale riavvio.

PLED (LED alimentazione del sistema):

Va collegato all'indicatore di stato d'alimentazione del pannello frontale del telaio. Il LED è acceso quando il sistema è operativo. Il LED continua a lampeggiare quando il sistema è in stato di standby S1. Il LED è spento quando il sistema è in stato di sospensione /ibernazione S3/S4 oppure spento (S5).

HDLED (LED attività disco rigido):

Va collegato al LED attività disco rigido del pannello frontale del telaio. Il LED è acceso quando disco rigido legge e scrive i dati.

Il design del pannello frontale può variare in base ai telai. Il modulo di un pannello frontale può consistere di: interruttore d'alimentazione, interruttore di ripristino, LED d'alimentazione, LED attività disco rigido, casse, eccetera. Quando si collega il modulo del pannello frontale a questo header, assicurarsi che l'assegnazione dei fili e dei pin sia fatta corrispondere in modo appropriato.

Collettore casse telaio

(4-pin SPEAKER1)
(vedi p.2 Nr. 7)

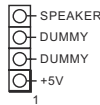

Collegare le casse del telaio a questo collettore.

Connettore ventolina Chassis

(4-pin CHA_FAN1)
(vedi p.2 Nr. 10)

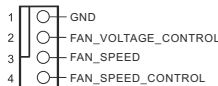

Collegare i cavi della ventola ai corrispondenti connettori facendo combaciare il cavo nero col pin di terra.

Connettore ventolina CPU

(4-pin CPU_FAN1)
(vedi p.2 Nr. 2)

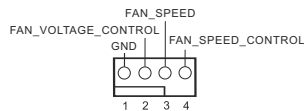

Collegare il cavo della ventolina CPU a questo connettore e far combaciare il filo nero al pin terra.



Sebbene la presente scheda madre disponga di un supporto per ventola CPU a 4 piedini (ventola silenziosa), la ventola CPU a 3 piedini è in grado di funzionare anche senza la funzione di controllo della velocità della ventola. Se si intende collegare la ventola CPU a 3 piedini al connettore della ventola CPU su questa scheda madre, collegarla ai piedini 1-3.

Piedini 1-3 collegati ←

Installazione della ventola a 3 piedini



Connettore alimentazione ATX

(24-pin ATXPWR1)

(vedi p.2 Nr. 5)

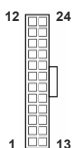

Collegare la sorgente d'alimentazione ATX a questo connettore.



Con questa scheda madre, c'è in dotazione un connettore elettrico ATX a 24 pin, ma può funzionare lo stesso se si adotta un alimentatore ATX a 20 pin. Per usare l'alimentatore ATX a 20 pin, collegare l'alimentatore con il Pin 1 e il Pin 13.



Installazione dell'alimentatore ATX a 20 pin

Connettore ATX 12 V

(4-pin ATX12V1)

(vedi p.2 Nr. 1)



Collegare un alimentatore ATX 12 V a questo connettore.

Header di intrusione dello chassis

(2-pin Cl1)

(vedi p.2 Nr. 23)



Questa scheda madre supporta la funzione di rilevamento del CASE APERTO che rileva che il coperchio dello chassis è stato rimosso. Questa funzione richiede un chassis con struttura di rilevamento di intrusione dello chassis.

Header TPM

(TPMS1 17 pin)

(vedi p.2 No. 6)

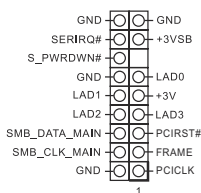

Questo connettore supporta il sistema Trusted Platform Module (TPM), che può archiviare in modo sicuro chiavi, certificati digitali, password e dati. Un sistema TPM permette anche di potenziare la sicurezza della rete, di proteggere identità digitali e di garantire l'integrità della piattaforma.

1. Introducción

Gracias por su compra de ASRock **FM2A88M Pro3+** placa madre, una placa de confianza producida bajo el control de calidad estricto y persistente. La placa madre provee realización excelente con un diseño robusto conforme al compromiso de calidad y resistencia de ASRock.

Esta Guía rápida de instalación contiene una introducción a la placa base y una guía de instalación paso a paso. Puede encontrar una información más detallada sobre la placa base en el manual de usuario incluido en el CD de soporte.



Porque las especificaciones de la placa madre y el software de BIOS podrían ser actualizados, el contenido de este manual puede ser cambiado sin aviso. En caso de cualquier modificación de este manual, la versión actualizada estará disponible en el website de ASRock sin previo aviso. También encontrará las listas de las últimas tarjetas VGA y CPU soportadas en la página web de ASRock.

Website de ASRock <http://www.asrock.com>

Si necesita asistencia técnica en relación con esta placa base, visite nuestra página web con el número de modelo específico de su placa. www.asrock.com/support/index.asp

1.1 Contenido de la caja

Placa base ASRock **FM2A88M Pro3+** (Factor forma Micro ATX)

Guía de instalación rápida de ASRock **FM2A88M Pro3+**

CD de soporte de ASRock **FM2A88M Pro3+**

Dos cables de datos Serial ATA (SATA) (Opcional)

Una protección I/O

1.2 Especificación

Plataforma	<ul style="list-style-type: none"> - Factor forma Micro ATX - Diseño de los Condensadores: Solid - PCB de fibra de vidrio de alta densidad
Procesador	- Admite zócalos de procesadores FM2+ 95W / FM2 100W
Chipset	- AMD A88X (Bolton-D4)
Memoria	<ul style="list-style-type: none"> - Soporte de Tecnología de Memoria de Doble Canal - 4 x DDR3 DIMM slots - Apoya DDR3 2400+(OC)/2133/1866/1600/1333/1066 non-ECC, memoria de un-buffered - Máxima capacidad de la memoria del sistema: 64GB - Compatible con Intel® Extreme Memory Profile (XMP)1.3/1.2 - Admite tecnología de perfil de memoria AMD (AMP, Memory Profile Technology) hasta AMP 2400
Ranuras de Expansión	<ul style="list-style-type: none"> - 1 x ranura PCI Express 3.0 x16 (PCIE1: modo x16) * Solo se admite PCIE 3.0 con FM2+ CPU. Con FM2 CPU, solo se admite PCIE 2.0. - 2 x ranura PCI Express 2.0 x1 - Admite tarjeta gráfica dual
VGA OnBoard	<ul style="list-style-type: none"> - Gráficos integrados de serie R7/R5, HD AMD Radeon™ con APU de serie A - DirectX 11.1, Sombreador de píxeles 5.0 con FM2+ CPU. - DirectX 11, Sombreador de píxeles 5.0 con FM2 CPU. - 2GB de Memoria máxima compartida - Tres opciones de salida VGA: D-Sub, DVI-D y HDMI - Compatible con monitores triples - Admite HDMI con una resolución máxima de 4K x 2K (4096x2160) a 24 Hz * Sólo FM2 + APU puede soportar hasta 4096x2160 resolución de la pantalla a través del puerto HDMI. - Admite Dual-link DVI-D con una resolución máxima de 2560x1600 a 60 Hz - Admite D-Sub con una resolución máxima de 1920x1200 a 60 Hz - Admite Sincronización automática entre audio y vídeo, Deep Color (12 bpc), xvYCC y HBR (audio de alta tasa de bits) con HDMI (se necesita un monitor compatible con HDMI) - Admite la función 3D estereoscópica Blu-ray con HDMI

	<ul style="list-style-type: none"> - Admite AMD Steady Video™ 2.0: Nueva capacidad de pospro cesamiento de vídeo para reducción automática de oscilaciones en vídeo doméstico y en línea - Admite la función HDCP con puertos DVI-D y HDMI - Apoya la reproducción de Blu-ray de 1080p (BD) con puertos DVI-D y HDMI
Audio	<ul style="list-style-type: none"> - 5.1 Audio CH HD (Realtek ALC662 Audio Codec) - Admite protección contra subidas de tensión (Protección Integral contra Picos de ASRock) - ELNA Audio Caps.
LAN	<ul style="list-style-type: none"> - LAN Gigabit PCIE x1 10/100/1000 Mb/s - Realtek RTL8111GR - Admite Reactivación en WAN - Compatible con Wake-On-LAN - Supporto la protezione da fulmini/scariche elettrostatiche (ESD) (protezione completa ASRock dai picchi di corrente) - Admite detección de conexión de cable LAN - Compatible con Ethernet de consumo eficiente de energía 802.3az - Compatible con PXE
Entrada/Salida de Panel Trasero	<ul style="list-style-type: none"> - 1 x Puerto de ratón PS/2 - 1 x Puerto de teclado PS/2 - 1 x Puerto D-Sub - 1 x Puerto DVI-D - 1 x Puerto HDMI - 4 x puertos USB 2.0 predeterminados (Admite protección ESD (Protección Integral contra Picos de ASRock)) - 2 x puertos USB 3.0 predeterminados (AMD A88X (Bolton-D4)) (Admite protección ESD (Protección Integral contra Picos de ASRock)) - 1 x Puerto LAN RJ-45 con LED (LED de ACCIÓN/ ENLACE y LED de VELOCIDAD) - Conexión de audio: Entrada de línea / Altavoz frontal / Micrófono
Almacenamiento	<ul style="list-style-type: none"> - 8 x conectores SATA3 de 6,0 Gb/s compatibles con funciones RAID (RAID 0, RAID 1, RAID 5 y RAID 10), NCQ, AHCI y de "conexión en caliente" compatibles con funciones NCQ, AHCI y de "conexión en caliente"

Conectores	<ul style="list-style-type: none"> - 1 x Conector de detección de intrusión en el chasis - 1 x cabezal TPM - 1 x Conector de ventilador de CPU (4-pin) - 1 x Conector de ventilador de chasis (4-pin) - 1 x 24-pin cabezal de alimentación ATX - 1 x 4-pin conector de ATX 12V power - 1 x Conector de audio de panel frontal - 2 x Cabezal USB 2.0 (admite 4 puertos USB 2.0 adicionales) (Admite protección ESD (Protección Integral contra Picos de ASRock)) - 1 x Cabezal USB 3.0 de AMD A88X (Bolton-D4) (admite 2 puertos USB 3.0 adicionales) (Admite protección ESD (Protección Integral contra Picos de ASRock))
BIOS	<ul style="list-style-type: none"> - 64Mb AMI BIOS legal UEFI AMI compatible con GUI - Soporta "Plug and Play" - ACPI 1.1 compliance wake up events - Soporta "jumper free setup" - Soporta SMBIOS 2.3.1 - Múltiple ajuste de DRAM y CPU Voltage
Monitor Hardware	<ul style="list-style-type: none"> - Sensor de temperatura de la CPU - Sensor de temperatura de la Chasis - Tacómetro del ventilador de CPU - Tacómetro del ventilador de Chasis - CPU/Chasis Ventilador silencioso - Control multivelocidad del ventilador de CPU/Chasis - Control de APERTURA DE CARCASA - Monitor de Voltaje: +12V, +5V, +3.3V, Vcore
OS	<ul style="list-style-type: none"> - En conformidad con Microsoft® Windows® 8.1 32 bits / 8.1 64 bits / 8 32 bits / 8 64 bits / 7 32 bits / 7 64 bits
Certificaciones	<ul style="list-style-type: none"> - FCC, CE, WHQL - Cumple con la directiva ErP/EuP (se requiere una fuente de alimentación que cumpla con la directiva ErP/EuP)



* Para más información sobre los productos, por favor visite nuestro sitio web:

<http://www.asrock.com>

1.3 Setup de Jumpers

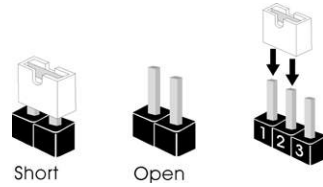
La ilustración muestra como los jumpers son configurados. Cuando haya un jumper cap sobre los pins, se dice que el jumper está "Short". No habiendo jumper cap sobre los pins, el jumper está "Open". La ilustración muestra un jumper de 3 pins cuyo pin 1 y pin 2 están "Short".



Jumper	Setting
Limpiar CMOS (CLRCMOS1, jumper de 3 pins) (ver p.2, No. 22)	<div style="display: flex; justify-content: space-around;"> <div style="text-align: center;"> <p>1_2</p>  <p>Valor predeterminado</p> </div> <div style="text-align: center;"> <p>2_3</p>  <p>Restablecimiento de la CMOS</p> </div> </div>

Nota: CLRCMOS1 permite borrar los datos de la memoria CMOS. Para borrar los parámetros del sistema y restablecer la configuración predeterminada de los mismos, apague el equipo y desenchufe el cable de alimentación de la toma de corriente eléctrica. Deje que transcurran 15 segundos y, después, utilice un puente para cortocircuitar los contactos 2 y 3 de CLRCMOS1 durante 5 segundos. No borre la memoria CMOS justamente después de actualizar el BIOS. Si necesita borrar la memoria CMOS justamente después de actualizar el BIOS, debe iniciar primero el sistema y, a continuación, cerrarlo antes de llevar a cabo el borrado de dicha memoria. Tenga en cuenta que la contraseña, la fecha, la hora, el perfil predeterminado del usuario, el GUID 1394 y la dirección MAC solamente se borrarán si la batería CMOS se quita.



Si borra la memoria CMOS, se puede detectar un caso de abertura. Ajuste la opción del BIOS "Clear Status" (Borrar estado) para borrar el registro del estado de intrusión anterior del chasis.

1.4 Cabezales y Conectores en Placas



Los conectores y cabezales en placa NO son puentes. NO coloque las cubiertas de los puentes sobre estos cabezales y conectores. El colocar cubiertas de puentes sobre los conectores y cabezales provocará un daño permanente en la placa base.

Conexiones de serie ATA3

(SATA_1: vea p.2, N. 16)

(SATA_2: vea p.2, N. 15)

(SATA_3: vea p.2, N. 14)

(SATA_4: vea p.2, N. 13)

(SATA_5: vea p.2, N. 12)

(SATA_6: vea p.2, N. 11)

(SATA_7: vea p.2, N. 9)

(SATA_8: vea p.2, N. 8)



Estas ocho conexiones de serie ATA3 (SATA3) admiten cables SATA para dispositivos de almacenamiento internos. La interfaz SATA3 actual permite una velocidad de transferencia de 6.0 Gb/s.

Cabezal USB 2.0

(9-pin USB_6_7)

(vea p.2, N. 18)

(9-pin USB_8_9)

(vea p.2, N. 19)

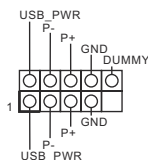

Además de cuatro puertos USB 2.0 predeterminados en el panel de E/S, hay dos bases de conexiones USB 2.0 en esta placa base. Cada una de estas bases de conexiones admite dos puertos USB 2.0.

Cabezal USB 3.0

(19-pin USB_10_11)

(vea p.2, N. 20)

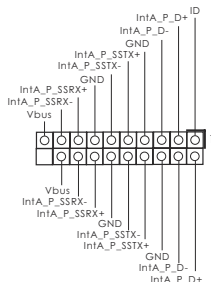

Además de dos puertos 3.0 predeterminados situados en el panel E/S, encontrará una cabecera USB 3.0 en esta placa base. Esta cabecera USB 3.0 admiten dos puertos USB 3.0.

Conector de audio de panel frontal
(9-pin HD_AUDIO1)
(vea p.2, N. 21)

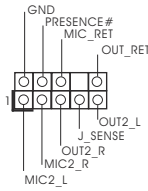

Este es una interface para cable de audio de panel frontal que permite conexión y control conveniente de aparatos de Audio.



1. El Audio de Alta Definición soporta la detección de conector, pero el cable de panel en el chasis debe soportar HDA para operar correctamente. Por favor, siga las instrucciones en nuestro manual y en el manual de chasis para instalar su sistema.
2. Si utiliza el panel de sonido AC'97, instálelo en la cabecera de sonido del panel frontal de la siguiente manera:
 - A. Conecte Mic_IN (MIC) a MIC2_L.
 - B. Conecte Audio_R (RIN) a OUT2_R y Audio_L (LIN) en OUT2_L.
 - C. Conecte Ground (GND) a Ground (GND).
 - D. MIC_RET y OUT_RET son sólo para el panel de sonido HD. No necesitará conectarlos al panel de sonido AC'97.
 - E. Activación del micrófono frontal.

En sistemas operativos Windows® 8.1 / 8.1 64-bit / 8 / 8 64-bit / 7 / 7 64-bit:

Acceda a la ficha "FrontMic" (Micrófono frontal) del panel de control Realtek. Ajuste la posición del control deslizante "Recording Volume" (Volumen de grabación).

Cabezal de panel de sistema
(9-pin PANEL1)
(vea p.2, N. 17)

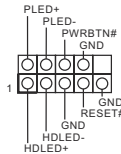

Este cabezar acomoda varias dunciones de panel frontal de sistema.



Conecte el interruptor de alimentación, el interruptor de restablecimiento y el indicador de estado del sistema situados en el chasis con esta cabecera en función de las siguientes asignaciones de contacto. Preste atención a los contactos positivos y negativos antes de conectar los cables.

PWRBTN (interruptor de alimentación):

Conecte el interruptor de encendido situado en el panel frontal del chasis. Puede configurar la forma de apagar su sistema mediante el interruptor de alimentación.

RESTABLECER (interruptor de restablecimiento):

Conecte el interruptor de restablecimiento situado en el panel frontal del chasis. Pulse el interruptor de restablecimiento para restablecer el equipo si se bloquea y no se reinicia con normalidad.

PLED (LED de alimentación del sistema):

Conecte el indicador de estado de alimentación situado en el panel frontal del chasis. El LED se enciende cuando el sistema esté en funcionamiento. El LED parpadea cuando el sistema se encuentre en estado de suspensión S1. El LED se apaga cuando el sistema se encuentre en estado de suspensión S3/S4 o se apaga (S5).

HDLED (LED de actividad del disco duro):

Conecte el LED de actividad de disco duro situado en el panel frontal del chasis. El LED se enciende cuando el disco duro esté leyendo o escribiendo datos.

Es posible que el diseño del panel frontal varíe en función del chasis. Un módulo del panel frontal consiste principalmente de interruptor de alimentación, interruptor de restablecimiento, LED de alimentación, LED de actividad del disco duro, altavoz, etc. Al conectar el módulo del panel frontal del chasis a esta cabecera, asegúrese de que las asignaciones de cables y las asignaciones de contactos coincidan correctamente.

Cabezal del altavoz del chasis

(4-pin SPEAKER1)

(vea p.2, N. 7)

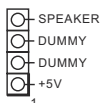

Conecte el altavoz del chasis a su cabezal.

Conector del ventilador de la chasis

(4-pin CHA_FAN1)

(vea p.2, N. 10)

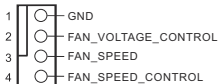

Por favor, conecte los cables del ventilador a los conectores de ventilador, haciendo coincidir el cable negro con la patilla de masa.

Conector del ventilador de la CPU

(4-pin CPU_FAN1)

(vea p.2, N. 2)

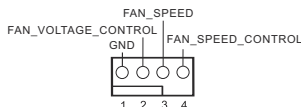

Conecte el cable del ventilador de la CPU a este conector y haga coincidir el cable negro con el conector de tierra.



Aunque esta placa base proporciona compatibilidad para un ventilador (silencioso) de procesador de 4 contactos, el ventilador de procesador de 3 contactos seguirá funcionando correctamente incluso sin la función de control de velocidad del ventilador. Si pretende enchufar el ventilador de procesador de 3 contactos en el conector del ventilador de procesador de esta placa base, conéctelo al contacto 1-3.

Contacto 1-3 conectado ←

Instalación del ventilador de 3 contactos

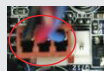

Cabezal de alimentación ATX
(24-pin ATXPWR1)
(vea p.2, N. 5)

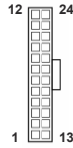

Conecte la fuente de alimentación ATX a su cabezal.



A pesar de que esta placa base incluye un conector de alimentación ATX de 24 pines, ésta puede funcionar incluso si utiliza una fuente de alimentación ATX de 20 pines tradicional. Para usar una fuente de alimentación ATX de 20 pines, por favor, conecte su fuente de alimentación usando los Pines 1 y 13.



Instalación de una Fuente de Alimentación ATX de 20 Pines

Conector de ATX 12V power
(4-pin ATX12V1)
(vea p.2, N. 1)



Tenga en cuenta que es necesario conectar este conector a una toma de corriente con el enchufe ATX 12V, de modo que proporcione suficiente electricidad. De lo contrario no se podrá encender.

Conector de detección de intrusión en el chasis
(2-pin CI1)
(vea p.2, N. 23)



Esta placa base admite la función de control de APERTURA DE CARCASA, que permite detectar si se ha retirado la cubierta del chasis. Dicha función requiere un chasis con diseño específico para la detección de intrusión en el chasis.

Cabezal TPM
(TPMS1 de 17 terminales)
(vea p.2, N. 6)

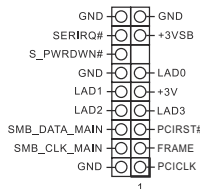

Este conector es compatible con el sistema Módulo de Plataforma Segura (TPM, en inglés), que puede almacenar de forma segura claves, certificados digitales, contraseñas y datos. Un sistema TPM también ayuda a aumentar la seguridad en la red, protege identidades digitales y garantiza la integridad de la plataforma.

1. Введение

Благодарим вас за покупку материнской платы ASRock **FM2A88M Pro3+** надежной материнской платы, изготовленной в соответствии с постоянно предъявляемыми ASRock жесткими требованиями к качеству. Она обеспечивает превосходную производительность и отличается отличной конструкцией, которые отражают приверженность ASRock качеству и долговечности.

Данное руководство по быстрой установке включает вводную информацию о материнской плате и пошаговые инструкции по ее установке. Более подробные сведения о плате можно найти в руководстве пользователя на компакт-диске поддержки.



Спецификации материнской платы и программное обеспечение BIOS иногда изменяются, поэтому содержание этого руководства может обновляться без уведомления. В случае любых модификаций руководства его новая версия будет размещена на веб-сайте ASRock без специального уведомления. Кроме того, самые свежие списки поддерживаемых модулей памяти и процессоров можно найти на сайте ASRock.

Адрес веб-сайта ASRock <http://www.asrock.com>

При необходимости технической поддержки по вопросам данной материнской платы посетите наш веб-сайт для получения информации об используемой модели.

www.asrock.com/support/index.asp

1.1 Комплектность

Материнская плата ASRock **FM2A88M Pro3+** (форм-фактор Micro ATX)

Руководство по быстрой установке ASRock **FM2A88M Pro3+**

Компакт-диск поддержки ASRock **FM2A88M Pro3+**

2 x кабель данных Serial ATA (SATA) (дополнительно)

1 x I/O Щит Группы ввода / вывода

1.2 Спецификации

Платформа	<ul style="list-style-type: none"> - форм-фактор Micro ATX - Использование только твердотельных конденсаторов - High Density Glass Fabric PCB
Процессор	- Поддержка разъема FM2+ 95 Вт / процессоров FM2 100 Вт
Набор микросхем	- AMD A88X (Bolton-D4)
Память	<ul style="list-style-type: none"> - Поддержка технологии Dual Channel DDR3 Memory Technology - 4 x гнезда DDR3 DIMM - Поддержите DDR3 2400+(OC)/2133/1866/1600/1333/1066 не- ECC, безбуферная память - Макс. 64 Гб - Поддержка профиля Intel® Extreme Memory Profile (XMP)1.3/1.2 - Поддержка технологии AMD Memory Profile (AMP) до AMP 2400
Гнезда расширения	<ul style="list-style-type: none"> - 1 x слота PCI Express 3.0 x16 (PCIЕ1: режим x16) * PCIЕ 3.0 поддерживается только с процессором FM2+. С процессором FM2 поддерживается только PCIЕ 2.0. - 2 x гнезда PCI Express 2.0 x1 - Поддерживаются режимы AMD двойные видеокарты
Графика	<ul style="list-style-type: none"> - Встроенный процессор AMD Radeon™ серии R7/R5 с графикой в APU серии A - DirectX 11.1, Pixel Shader 5.0 с процессором FM2+. DirectX 11, Pixel Shader 5.0 с процессором FM2. - Макс. объем разделяемой памяти 2GB - Три VGA-выхода: D-Sub, DVI-D и HDMI - Поддержка работы с тремя мониторами - Поддержка HDMI с максимальным разрешением до 4K x 2K (4096x2160) @ 24 Гц * Разрешение 4096x2160 через порт HDMI поддерживается только процессорами FM2+ APU. - Поддержка Dual-link DVI-D с максимальным разрешением до 2560x1600 @ 60 Гц - Поддержка D-Sub с максимальным разрешением до 1920x1200 @ 60 Гц - Поддержка Auto Lip Sync, Deep Color (12 бит на цветовой канал), xvYCC и HBR (High Bit Rate Audio) через HDMI (необходим монитор с разъемом HDMI) - Поддержка стандарта Blu-ray Stereoscopic 3D со спецификацией HDMI - Поддержка технологии AMD Steady Video™ 2.0: новая функция постобработки видеоизображения для автоматического устранения дрожания при просмотре домашних и онлайн-видео записей - Поддержка функции HDCP через разъемы DVI-D и HDMI - Поддержат Blu-ray 1080p (КОММУТАЦИОННАЯ ДОСКА) через разъемы DVI-D и HDMI

Аудиосистема	<ul style="list-style-type: none"> - 5.1-канальный звук высокой четкости HD Audio (аудиокодек Realtek ALC662) - Поддержка защиты от перенапряжений (Полная защита (ASRock от выбросов напряжения)) - ELNA Audio Caps.
ЛВС	<ul style="list-style-type: none"> - PCIe x1 Gigabit LAN 10/100/1000 Мб/с - Realtek RTL8111GR - Поддержка Wake-On-WAN - Поддержка Wake-On-LAN - Поддержка защиты от перенапряжений (Полная защита (ASRock от выбросов напряжения)) - Поддержка определения кабеля ЛВС - Поддержка Energy Efficient Ethernet 802.3az - Поддержка PXE
Разъемы ввода-вывода на задней панели	<ul style="list-style-type: none"> - 1 x PS/2 мышь клавиатуры - 1 x PS/2 для клавиатуры - 1 x D-Sub порт - 1 x DVI-D порт - 1 x HDMI порт - 4 x порта USB 2.0 на задней панели в стандартной конфигурации с защитой от электростатического напряжения (ASRock Full Spike Protection) - 2 x порта USB 3.0 на задней панели в стандартной конфигурации (AMD A88X (Bolton-D4)) с защитой от электростатического напряжения (ASRock Full Spike Protection) - Разъем 1 x RJ-45 LAN с светодиодным индикатором (индикатор ACT/LINK и индикатор SPEED) - Соединитель звуковой подсистемы: линейный вход / передняя колонка / микрофон
Запоминающие устройства	<ul style="list-style-type: none"> - 8 x разъемы SATA3 6,0 Гбит/с, поддержка функций RAID (RAID 0, RAID 1, RAID 5 и RAID 10), NCQ, AHCI и «горячего подключения» - 1 x разъем датчика открытой крышки
Колодки и плате	<ul style="list-style-type: none"> - 1 x колодка TPM - 1 x соединитель CPU FAN (4-контактный) - 1 x соединитель Chassis FAN (4-контактный) - 1 x 24-контактный Колодка питания ATX - 1 x 4-контактный Разъем ATX 12 В - 1 x Аудиоразъем передней панели - 2 x Колодка USB 2.0 (одна колодка для поддержки 4 дополнительных портов USB 2.0 с защитой от электростатического напряжения (ASRock Full Spike Protection)) - 1 x Колодка USB 3.0 AMD A88X (Bolton-D4) (одна колодка для поддержки 2 дополнительных портов USB 3.0) с защитой от электростатического напряжения (ASRock Full Spike Protection)

BIOS	<ul style="list-style-type: none"> - 64Mb AMI UEFI Legal BIOS с поддержкой графического интерфейса поль зователя - поддержка "Plug and Play" - ACPI 1.1, включение по событиям - поддержка режима настройки без перемычек - поддержка SMBIOS 2.3.1 - Регулировка напряжений DRAM и CPU
Контроль оборудования	<ul style="list-style-type: none"> - Датчик температуры ЦП - Датчик температуры корпуса - Тахометр вентиляторов ЦП питания - Тахометр вентиляторов корпуса питания - Бесшумный вентилятор ЦП/корпуса - Управление оборотами вентилятора ЦП/корпуса - Определение открытой крышки - Контроль напряжения: +12V, +5V, +3.3V, Vcore
Операционные системы	- Совместимость с Microsoft® Windows® 8.1 32-bit / 8.1 64-bit / 8 32-bit / 8 64-bit / 7 32-bit / 7 64-bit
Сертификаты	<ul style="list-style-type: none"> - FCC, CE, WHQL - Совместимость с EoP/EuP Ready (требуется блок питания совместимый с EoP/EuP)

* Для детальной информации продукта, пожалуйста посетите наш вебсайт:

<http://www.asrock.com>

1.3 Установка перемычек

Конфигурация перемычек иллюстрируется на рисунке. Когда перемычка надета на контакты, они называются “замкнутыми” (short). Если на контактах перемычки нет, то они называются “разомкнутыми” (open). На иллюстрации показана 3-контактная перемычка, у которой контакты 1 и 2 замкнуты.

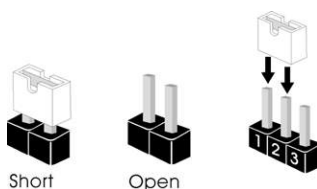

Перемычка	Установка	Описание
Очистка CMOS (CLRCMOS1, 3-контактная перемычка) (см. стр. 2, п. 22)	 1_2 Стандартные	 2_3 Очистка CMOS

Примечание. Контактная колодка CLRCMOS1 позволяет очистить данные CMOS. Для очистки данных и восстановления заводских системных параметров сначала выключите компьютер и отсоедините сетевую вилку кабеля питания от электророзетки. Выждите не менее 15 секунд и колпачковой перемычкой на 5 секунд перемкните штырьки 2 и 3 контактной колодки CLRCMOS1. Однако не производите очистку CMOS непосредственно после обновления BIOS. Если необходимо очистить CMOS сразу же после окончания обновления BIOS, то, перед очисткой CMOS, необходимо сначала выполнить загрузку системы, а затем завершить ее работу. Примите во внимание, что пароль, дата, время, профиль пользователя по умолчанию, идентификатор 1394 GUID и MAC-адрес будут очищены только тогда, когда будет извлечена из своего гнезда батарейка CMOS.



Очистка CMOS может вызвать срабатывание датчика открытой крышки. Измените опцию «Clear Status» в BIOS, чтобы очистить записи о предыдущих срабатываниях датчика.

1.4 Колодки и разъемы на плате



Имеющиеся на плате колодки и разъемы НЕ ЯВЛЯЮТСЯ контактами для перемычек. НЕ УСТАНАВЛИВАЙТЕ перемычки на эти колодки и разъемы – это приведет к необратимому повреждению материнской платы!

Разъемы Serial ATA3

- (SATA_1, см. стр. 2, п. 16)
- (SATA_2, см. стр. 2, п. 15)
- (SATA_3, см. стр. 2, п. 14)
- (SATA_4, см. стр. 2, п. 13)
- (SATA_5, см. стр. 2, п. 12)
- (SATA_6, см. стр. 2, п. 11)
- (SATA_7, см. стр. 2, п. 9)
- (SATA_8, см. стр. 2, п. 8)



восемь соединителя Serial ATA3 предназначаются для подключения внутренних устройств хранения с использованием интерфейсных кабелей SATA3. В настоящее время интерфейс SATA допускает скорость передачи данных до \ 6,0 Гбит/с.

Колодка USB 2.0

- (9-контактный USB_6_7)
- (см. стр. 2, п. 18)
- (9-контактный USB_8_9)
- (см. стр. 2, п. 19)

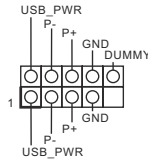

Помимо четыре стандартных портов USB 2.0 на панели ввода-вывода, на данной материнской плате предусмотрено два разъема USB 2.0. Каждый разъем USB 2.0 поддерживает два порта USB 2.0.

Колодка USB 3.0

- (19-контактный USB_10_11)
- (см. стр. 2, п. 20)

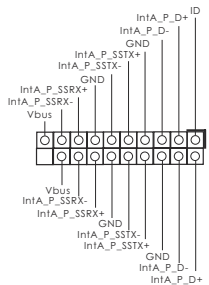

Помимо два стандартных портов USB 3.0 на панели ввода-вывода, на данной материнской плате предусмотрен один разъем USB 3.0. Этот разъем USB 3.0 поддерживает два порта USB 3.0.

Аудиоразъем передней панели

- (9-контактный HD_AUDIO1)
- (см. стр. 2, п. 21)

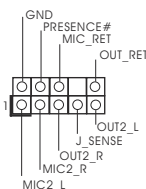

Этот интерфейс предназначен для присоединения аудиокабеля передней панели, обеспечивающего удобное подключение аудиоустройств и управление ими.



1. Система High Definition Audio поддерживает функцию автоматического обнаружения разъемов (Jack Sensing), однако для ее правильной работы аудио кабель панели в корпусе должен поддерживать HDA. При сборке системы следуйте инструкциям, приведенным в нашем руководстве и руководстве пользователя для корпуса.
2. Если вы используете аудиопанель AC'97, подключите ее к колодке аудиоинтерфейса передней панели следующим образом:
 - A. Подключите выводы Mic_IN (MIC) к контактам MIC2_L.
 - B. Подключите выводы Audio_R (RIN) к контактам OUT2_R, а выводы Audio_L (LIN) к контактам OUT2_L.
 - C. Подключите выводы Ground (GND) к контактам Ground (GND).
 - D. Контакты MIC_RET и OUT_RET предназначены только для аудиопанели HD. При использовании аудиопанели AC'97 подключать их не нужно.
 - E. Процедура активации микрофона приведена ниже.]
Для ОС Windows® 8.1 / 8.1 64-бита / 8 / 8 64-бита / 7 / 7 64-бита: Перейдите к вкладке «FrontMic» (Передний микрофон) в панели управления Realtek. Отрегулируйте уровень «Recording Volume» (Громкость записи).

Колодка системной панели
(9-контактный PANEL1)
(см. стр. 2, п. 17)

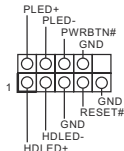

Данная колодка обеспечивает работу нескольких функций передней панели системы.



Подключите к этому разъему кнопку питания, кнопку сброса и индикатор состояния системы на корпусе в соответствии с указанным ниже назначением контактов. При подключении кабелей необходимо соблюдать полярность положительных и отрицательных контактов.

PWRBTN (кнопка питания):

Подключите к этим контактам кнопку питания на передней панели корпуса. Способ выключения системы с помощью кнопки питания можно настроить.

RESET (кнопка сброса):

Подключите к этим контактам кнопку сброса на передней панели корпуса. Нажмите кнопку сброса для перезагрузки компьютера, если компьютер «завис» и нормальную перезагрузку выполнить не удастся.

PLED (индикатор питания системы):

Подключите к этим контактам индикатор состояния питания на передней панели корпуса. Этот индикатор светится, когда система работает. Индикатор мигает, когда система находится в режиме ожидания S1. Этот индикатор не светится, когда система находится в режиме ожидания S3 или S4, либо выключена (S5).

HDLED (индикатор активности жесткого диска):

Подключите к этим контактам индикатор активности жесткого диска на передней панели корпуса. Этот индикатор светится, когда осуществляется считывание или запись данных на жестком диске.

Конструкция передней панели может различаться в зависимости от корпуса. Модуль передней панели в основном состоит из кнопки питания, кнопки сброса, индикатора питания, индикатора активности жесткого диска, динамика и т.п. При подключении к этому разъему модуля передней панели корпуса удостоверьтесь, что провода подключаются к соответствующим контактам.

Колодка динамика корпуса
(4-контактный SPEAKER1)
(см. стр. 2, п. 7)

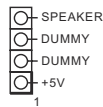

Подключите к этой колодке кабель от динамика на корпусе компьютера.

Chassis Fan-соединители
(4-контактный CHA_FAN1)
(см. стр. 2, п. 10)

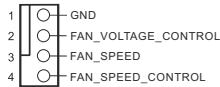

Подключите кабели вентилятора к соединителям и присоедините черный шнур к штырю заземления.

Разъем вентилятора процессора
(4-контактный CPU_FAN1)
(см. стр. 2, п. 2)

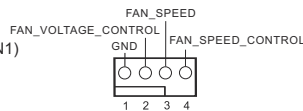

Подключите к этому разъему кабель вентилятора процессора так, чтобы черный провод соответствовал контакту земли.



Данная материнская плата поддерживает вентиляторы процессора с 4-контактным разъемом (функция тихого режима вентилятора), однако вентиляторы с 3-контактным разъемом также будут успешно работать, хотя функция управления скоростью вращения вентилятора окажется недоступной. Если вы хотите подключить вентилятор процессора с 3-контактным разъемом к разъему вентилятора процессора на данной материнской плате, для этого следует использовать контакты 1-3.

Контакты 1-3 подключены ←

Установка вентилятора с 3-контактным разъемом



Колодка питания ATX
(24-контактный ATXPWR1)
(см. стр. 2, п. 5)

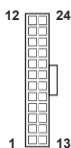

Подключите к этой колодке кабель питания ATX.



Несмотря на то, что эта материнская плата предусматривает 24-штыревой разъем питания ATX, работа будет продолжаться, даже если адаптируется традиционный 20-штыревой разъем питания ATX. Для использования 20-штыревого разъема питания ATX вставьте источник питания вместе со штекером 1 и штекером 13.

Установка 20-штыревого разъема питания ATX



Колодка питания 12V-ATX
(4-контактный ATX12V1)
(см. стр. 2, п. 1)



Обратите внимание, что к этому разъему необходимо подключить вилку блока питания ATX 12 В, чтобы обеспечить достаточную мощность электропитания. В противном случае включение системы будет невозможно.

Датчик открытой крышки
(2-контактный C11)
(см. стр. 2, п. 23)



Эта материнская плата поддерживает функцию определения открытой крышки, которая позволяет определить, была ли снята крышка корпуса. Функция требует поддержку со стороны корпуса.

Колодка TPM
(17-выводов TPMS1)
(см. стр. 2, п. 6)

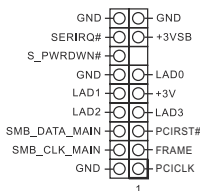

Этот разъем обеспечивает поддержку системы Trusted Platform Module (TPM), которая способна обеспечить надежное хранение ключей, цифровых сертификатов, паролей и данных. Система TPM также повышает уровень сетевой безопасности, защищает цифровые идентификаторы и обеспечивает целостность платформ.

1. Introdução

Gratos por comprar nossa placa-mãe **FM2A88M Pro3+** um produto confiável feito com ASRock um estrito controle de qualidade consistente. Com um excelente desempenho, essa placa é dotada de um projeto robusto que atende a ASRock de compromisso com a qualidade e durabilidade.

Este Guia de Instalação Rápida apresenta a placa-mãe e o guia de instalação passo a passo. Mais informações detalhadas sobre a placa-mãe podem ser encontradas no manual do usuário do CD de suporte.



Porque as especificações da placa mãe e o software de BIOS poderiam ser atualizados, o conteúdo deste manual pode ser cambiado sem aviso. Em caso de qualquer modificação deste manual, a versão atualizada estará disponível no website de ASRock sem prévio aviso. Pode também encontrar as listas das mais recentes placas VGA e das CPUs suportadas no site da web da ASRock.

Website de ASRock <http://www.asrock.com>

Se precisar de apoio técnico em relação a este placa-mãe, por favor visite o nosso sítio da internet para informação específica acerca do modelo que está a utilizar.

www.asrock.com/support/index.asp

1.1 Este pacote contém

Placa-mãe ASRock **FM2A88M Pro3+** (Formato Micro ATX)

Guia de instalação rápida da ASRock **FM2A88M Pro3+**

CD de suporte da placa ASRock **FM2A88M Pro3+**

Dois cabo de dados ATA Serial (SATA) (Opcional)

Uma proteção I/O

1.2 Especificações

Plataforma	<ul style="list-style-type: none"> - Formato Micro ATX - Design de condensador sólido - PCB de Fibra de Vidro de Alta Densidade
CPU	- Suporta processadores com Socket FM2+ a 95W / FM2 a 100W
Chipsets	- AMD A88X (Bolton-D4)
Memória	<ul style="list-style-type: none"> - Suporte à tecnologia de memória de duplo canal - 4 x slots de DDR3 DIMM - Suporta memória DDR3 2400+(OC)/2133/1866/1600/1333/1066, não ECC, sem tampão - Capacidade máxima de memória do sistema: 64GB - Suporta Extreme Memory Profile (XMP) 1.3/1.2 da Intel® - Suporta Tecnologia de Perfil de Memória AMD (AMP) até AMP 2400
Slots de Expansão	<ul style="list-style-type: none"> - 1 x slot de PCI Express 3.0 x16 (PCIE1: modo x16) * PCIE 3.0 é suportado apenas com CPU FM2+. CPU FM2 suporta apenas PCIE 2.0. - 2 x slot de PCI Express 2.0 x1 - Suporta Dual Graphics da AMD
VGA integrado	<ul style="list-style-type: none"> - Placa gráfica integrada AMD Radeon™ série R7/R5 na APU série A - DirectX 11.1, Pixel Shader 5.0 com CPU FM2+. DirectX 11, Pixel Shader 5.0 com CPU FM2. - Memória partilhada máxima 2GB - Três opções de saída VGA: D-Sub, DVI-D e HDMI - Suporta configuração com três monitores - Suporta HDMI Tecnologia com resolução máxima até 4K x 4K (4096x2160) @ 24Hz * Apenas APU FM2+ pode suportar resolução de até 4096x2160 via porta HDMI. - Suporta Dual-link DVI-D com resolução máxima até 2560x1600 @ 60Hz - Suporta D-Sub com resolução máxima até 1920x1200 @ 60Hz - Suporta as funções Auto Lip Sync (Sincronização automática do som), Deep Color (Profundidade da cor) (12bpc), xvYCC e HBR (áudio de taxa de bits elevada) com HDMI (é necessário um monitor compatível com a norma HDMI) - Suporta 3D Estereoscópico Blu-ray com HDMI

	<ul style="list-style-type: none"> - Suporta AMD Steady Video™ 2.0: Nova capacidade de pós-processamento de vídeo para redução automática de vibrações em vídeo local/online - Suporta função HDCP com portas DVI-D e HDMI - Suporta a norma Blu-ray de alta definição 1080p (BD) com portas DVI-D e HDMI
Áudio	<ul style="list-style-type: none"> - Áudio HD de 5.1 canais (Codec de áudio Realtek ALC662) - Suporta Proteção Contra Surto (Proteção Total contra Picos ASRock) - ELNA Audio Caps.
LAN	<ul style="list-style-type: none"> - LAN Gigabit 10/100/1000 Mb/s PCIE x1 - Realtek RTL8111GR - Suporta Wake-On-WAN - Suporta Wake-On-LAN - Suporta Proteção contra Relâmpago/ESD (Proteção Total contra Picos ASRock) - Suporta Detecção de cabo LAN - Suporta IEEE 802.3az - Suporta PXE
Entrada/Saída pelo painel	<ul style="list-style-type: none"> - 1 x Porta PS/2 para mouse - 1 x Porta PS/2 para teclado - 1 x porta D-Sub - 1 x porta DVI-D - 1 x porta HDMI - 4 x portas USB 2.0 padrão (Suporta Proteção ESD (Proteção Total contra Picos ASRock)) - 2 x portas USB 3.0 padrão (AMD A88X (Bolton-D4)) (Suporta Proteção ESD (Proteção Total contra Picos ASRock)) - 1 x porta LAN RJ-45 com LED (LED ACT/LIG e LED VELOCIDADE) - Ficha de áudio HD: Entrada de linha / Altifalante frontal / Microfone
Armazenamento	<ul style="list-style-type: none"> - 8 x conectores SATA3 a 6,0 Gb/s, com suporte para RAID (RAID 0, RAID 1, RAID 5 e RAID 10), NCQ, AHCI e funções Hot Plug

Conectores	<ul style="list-style-type: none"> - 1 x Conector de intrusão no chassis - 1 x Terminal TPM - 1 x Conector do ventilador da CPU (4 pinos) - 1 x Conector do ventilador da chassis (4 pinos) - 1 x Conector de força do ATX de 24 pinos - 1 x Conector ATX 12 V de 4 pinos - 1 x Conector Áudio do painel frontal - 2 x cabezal USB 2.0 (suporta 4 portas USB 2.0) (Suporta Proteção ESD (Proteção Total contra Picos ASRock)) - 1 x cabezal USB 3.0 pela AMD A88X (Bolton-D4) (suporta 2 portas USB 3.0) (Suporta Proteção ESD (Proteção Total contra Picos ASRock))
BIOS	<ul style="list-style-type: none"> - 64Mb BIOS UEFI oficial da AMI com suporte para GUI - Suporta dispositivos "Plug and Play" - ACPI 1.1 atendendo a eventos de "wake up" - Suporta dispositivos sem jumper - Suporte para SMBIOS 2.3.1 - DRAM e CPU Voltage Multi-adjustment
Monitor do HW	<ul style="list-style-type: none"> - Sensores de temperature do processador - Medição de temperatura da chassis - Tacômetros de ventilador do processador - Tacômetros de ventilador do chassis - Ventoinha silenciosa para a processador/chassis - Processador/chassis Fan Controle Multi-Velocidade - Detecção de CAIXA ABERTA - Monitoramento de voltagem: +12 V, +5 V, +3.3 V, Vcore
Sistema Operacional	<ul style="list-style-type: none"> - Microsoft® Windows® 8.1 de 32 bits / 8.1 de 64 bits / 8 de 32 bits / 8 de 64 bits / 7 de 32 bits / 7 de 64 bits
Certificações	<ul style="list-style-type: none"> - FCC, CE, WHQL - "ErP/EuP Ready" (é necessária alimentação eléctrica "ErP/EuP Ready")

* Para informações mais detalhadas por favor visite o nosso sítio Web: <http://www.asrock.com>

1.3 Configuração dos Jumpers

A ilustração mostra como os jumpers são configurados. Quando há uma capa de jumpers sobre os pinos, diz-se que o jumper está “curto”. Não havendo capa sobre os pinos, o jumper está “aberto”. A ilustração mostra um jumper de 3 pinos em que os pinos 1 e 2 estão “curtos” quando a capa de jumper estiver colocada sobre esses 2 pinos.

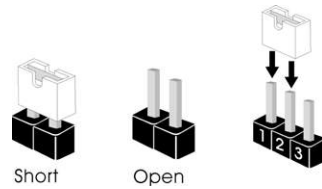

Jumper	Configuração
Restaurar CMOS (CLRCMOS1, jumper de 3 pinos) (veja a folha 2, No. 22)	<div style="display: flex; justify-content: space-around; align-items: center;"> <div style="text-align: center;"> <p>1_2</p> <p>Configuração-padrão</p> </div> <div style="text-align: center;"> <p>2_3</p> <p>Limpar o CMOS</p> </div> </div>

Nota: CLRCMOS1 permite você limpar os dados em CMOS. Os dados em CMOS incluem informações da configuração do sistema como: por exemplo a senha do sistema, data, tempo, e os parâmetros da configuração do sistema. Para limpar e reconfigurar os parâmetros do sistema a configuração inicial da fábrica, por favor desligue o cabo de força, ponha em curto-circuito os pin 2 e pin 3 de CLRCMOS1 por mais de 5 segundos para limpar o CMOS usando um jumper. Por favor lembre-se de remover o jumper depois de limpar o CMOS. Se precisar limpar o CMOS ao concluir a atualização do BIOS, deverá reiniciar o sistema primeiro e, em seguida, desligá-lo antes de executar a ação de limpeza o CMOS. Tenha em atenção que a palavra-passe, data, hora, perfil predefinido de utilizador, 1394 GUID e endereço MAC apenas serão limpos se a bateria do CMOS for retirada.



Se limpar o CMOS, poderá ser detectada a abertura da caixa. Ajuste a opção do BIOS “Clear Status” (Limpar estado) para limpar o registo anterior de estado de intrusão no chassis.

1.4 Conectores



Os conectores NÃO SÃO jumpers. NÃO coloque capas de jumper sobre estes conectores. A colocação de pontos de jumper sobre os conectores causará danos irreversíveis à placa-mãe.

Conectores ATA3 Serial

- (SATA_1: veja a folha 2, No. 16)
- (SATA_2: veja a folha 2, No. 15)
- (SATA_3: veja a folha 2, No. 14)
- (SATA_4: veja a folha 2, No. 13)
- (SATA_5: veja a folha 2, No. 12)
- (SATA_6: veja a folha 2, No. 11)
- (SATA_7: veja a folha 2, No. 9)
- (SATA_8: veja a folha 2, No. 8)



Estes oito conectores Serial ATA (SATA3) suportam unidades de disco rígido SATA ou SATA3 como dispositivos de armazenamento internos. A atual interface SATA3 permite uma taxa de transferência de dados de até 6.0 Gb/s.

Cabezal USB 2.0

- (USB_6_7 de 9 pinos)
(veja a folha 2, No. 18)
- (USB_8_9 de 9 pinos)
(veja a folha 2, No. 19)

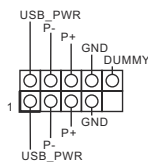

Além das quatro portas USB 2.0 por defeito no painel de entrada/saída, há dois ligações USB 2.0 nesta placa-mãe. Cada ligação USB 2.0 pode suportar dois portas USB 2.0.

Cabezal USB 3.0

- (USB_10_11 de 19 pinos)
(veja a folha 2, No. 20)

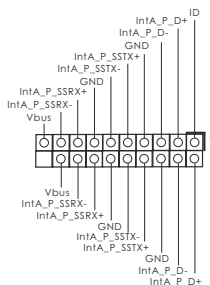

Além das duas portas USB 3.0 por defeito no painel de entrada/saída, há duas ligações USB 3.0 nesta placa-mãe. Cada ligação USB 3.0 pode suportar duas portas USB 3.0.

Conector Áudio do painel frontal

- (HD_AUDIO1 de 9 pinos)
(veja a folha 2, No. 21)

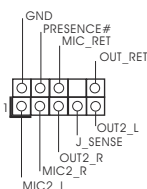

Esta é uma interface para o cabo de áudio no painel frontal, que permite uma conexão e controle convenientes dos dispositivos de áudio.



1. Áudio de elevada definição que suporta a sensibilidade da tomada, mas o fio do painel existente no chassis tem de suportar HDA para funcionar correctamente. Siga s instruções que aparecem no manual e no manual do chassis para instalar o sistema.
2. Se utilizar o painel de áudio AC'97, instale-o no cabeçalho de áudio do painel frontal, como a figura abaixo mostra:
 - A. Ligue o Mic_IN (MIC) ao MIC2_L.
 - B. Ligue o Audio_R (RIN) ao OUT2_R e o Audio_L (LIN) ao OUT2_L.
 - C. Ligue o Ground (GND) ao Ground (GND).
 - D. MIC_RET e OUT_RET são apenas para o painel de áudio HD. Não necessita de os ligar para o painel de áudio AC'97.
 - E. Para activar o microfone frontal.

Para os Sistemas Operativos Windows® 8.1 / 8.1 64-bit / 8 / 8 64-bit / 7 / 7 64-bit:

Aceda ao separador "Microfone frontal" no painel de Controlo Realtek. Ajuste o "Volume de gravação".

Conector do painel do sistema

(PANEL1 de 9 pinos)

(veja a folha 2, No. 17)

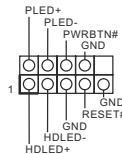

Este conector acomoda várias funções do painel frontal do sistema.



Ligue o botão de alimentação, o botão de reposição e o indicador do estado do sistema no chassis a este conector de acordo com a descrição abaixo. Tenha em atenção os pinos positivos e negativos antes de ligar os cabos.

PWRBTN (Botão de alimentação):

Ligue ao botão de alimentação no painel frontal do chassis. Pode configurar a forma para desligar o seu sistema através do botão de alimentação.

RESET (Botão de reposição):

Ligue ao botão de reposição no painel frontal do chassis. Prima o botão de reposição para reiniciar o computador caso este bloqueie e não seja possível reiniciar normalmente.

PLED (LED de alimentação do sistema):

Ligue ao indicador do estado da alimentação no painel frontal do chassis. O LED ficará acesso quando o sistema estiver em funcionamento. O LED ficará intermitente quando o sistema estiver no estado de suspensão S1. O LED ficará desligado quando o sistema estiver nos estados de suspensão S3/S4 ou desligado (S5).

HDLED (LED de actividade do disco rígido):

Ligue ao LED de actividade do disco rígido no painel frontal do chassis. O LED ficará acesso quando o disco rígido estiver a ler ou a escrever dados.

O design do painel frontal poderá variar dependendo do chassis. Um módulo de painel frontal consiste principalmente em um botão de alimentação, um botão de reposição, um LED de alimentação, um LED de actividade do disco rígido, um altifalante, etc. Ao ligar o seu módulo de painel frontal do chassis a este conector, certifique-se que os fios e os pinos têm uma correspondência exacta.

Conector do alto-falante do chassis

(SPEAKER1 de 4 pinos)
(veja a folha 2, No. 7)

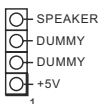

Ligue o alto-falante do chassis neste conector.

Conector do ventilador do chassis

(CHA_FAN1 de 4 pinos)
(veja a folha 2, No. 10)

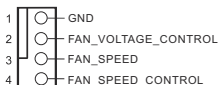

Ligue o cabo do ventilador neste conector, coincidindo o fio preto com o pino de aterramento.

Conector do ventilador da CPU

(CPU_FAN1 de 4 pinos)
(veja a folha 2, No. 2)

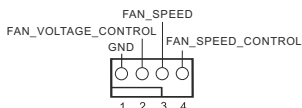

Ligue o cabo do ventilador da CPU, coincidindo o fio preto com o pino de aterramento.



Apesar de esta placa-mãe possuir 4 apoios para uma ventoinha de CPU (Ventoinha silenciosa), uma ventoinha de 3 pinos para CPU poderá funcionar mesmo sem a função de controlo de velocidade da ventoinha. Se pretender ligar uma ventoinha de 3 pinos para CPU ao conector de ventoinha do CPU nesta placa-mãe, por favor, ligue-a aos pinos 1-3.

Pinos 1-3 ligados ←

Instalação de Ventoinha de 3 pinos



Conector de força do ATX

(ATXPWR1 de 24 pinos)
(veja a folha 2, No. 5)

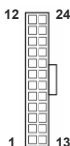

Ligue a fonte de alimentação ATX neste conector.



Embora esta placa-mãe providencie um conector de energia ATX de 24 pinos, pode apesar disso funcionar com a adaptação de uma fonte de energia tradicional de 20 pinos. Para usar a fonte de alimentação de 29 pinos, por favor ligue a sua fonte de alimentação com o Pino 1 e o Pino 13.

Instalação da Fonte de alimentação ATX de 20 Pinos



Conector de força do ATX 12V

(ATX12V1 de 4 pinos)

(veja a folha 2, No. 1)



Ligue a fonte de alimentação ATX 12V neste conector.

Conector de intrusão no chassis

(CI1 de 2 pinos)

(veja a folha 2, No. 23)



Esta placa principal suporta a função de detecção de ABERTURA da CAIXA quedetecta se a tampa do chassisfoi removida. Esta funçãorequer um chassis com designde detecção de intrusão.

Terminal TPM

(TPMS1 de 17 pinos)

(veja a folha 2, No. 6)

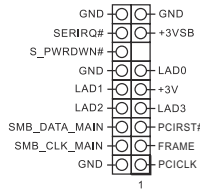

Este conector suporta um sistema com Módulo de Plataforma Confiável (TPM), que pode armazenar com segurança chaves, certificados digitais, palavras-passe e dados. Um sistema TPM também ajuda a melhorar a segurança de rede, a proteger identidades digitais e a garantir a integridade da plataforma.

1. Giriş

ASRock'ın kesintisiz titiz kalite denetimi altında üretilen güvenilir bir anakart olan ASRock **FM2A88M Pro3+** anakartını satın aldığınız için teşekkür ederiz. ASRock'ın kalite ve dayanıklılık konusundaki kararlılığına uygun güçlü tasarımıyla mükemmel bir performans sunar.

Bu Hızlı Takma Kılavuzu anakarta giriş ve adım adım takma kılavuzu içerir. Anakart hakkında daha ayrıntılı bilgiyi Destek CD'sinde sunulan kullanıcı kılavuzunda bulabilirsiniz.



Anakart özellikleri ve BIOS yazılımı güncelleştirilebileceğinden bu kılavuzun içeriği önceden haber verilmeksizin değişebilir. Bu belgede değişiklik yapılması durumunda, güncellenmiş sürüm ayrıca haber verilmeksizin ASRock web sitesinde sunulur. En son VGA kartlarını ve CPU destek listelerini de ASRock web sitesinde bulabilirsiniz. ASRock web sitesi <http://www.asrock.com>

Bu anakartla ilgili teknik desteğe ihtiyacınız olursa, kullandığınız modele özel bilgiler için lütfen web sitemizi ziyaret edin.

www.asrock.com/support/index.asp

1.1 Paket İçindekiler

ASRock **FM2A88M Pro3+** Anakart (Mikro ATX Form Faktörü)

ASRock **FM2A88M Pro3+** Hızlı Takma Kılavuzu

ASRock **FM2A88M Pro3+** Destek CD'si

2 x Seri ATA (SATA) Veri Kablosu (İsteğe Bağlı)

1 x G/Ç Panel Kalkanı

1.2 Özellikler

Platform	<ul style="list-style-type: none"> - Mikro ATX Form Faktörü - Tam Katı Bağlayıcı tasarımı - Yüksek Yoğunluklu Cam Elyafı Kumaş PCB
CPU	- Yuva FM2+ 95W / FM2 100W işlemciler için destek
Yonga seti	- AMD A88X (Bolton-D4)
Bellek	<ul style="list-style-type: none"> - Çift Kanallı DDR3 Belleği Teknolojisi - 4 x DDR3 DIMM yuva - DDR3 2400+(OC)/2133/1866/1600/1333/1066 ECC olmayan, ara belleksiz bellek - Sistem belleğinin maks. kapasitesi: 64 GB - Intel® Extreme Bellek Profilini (XMP)1.3/1.2 destekler - AMP 2400'e kadar AMD Bellek Profili Teknolojisini (AMP) destekler
Genişletme Yuvası	<ul style="list-style-type: none"> - 1 x PCI Express 3.0 x16 yuva (PCIE1: x16 modu) * PCIE 3.0 yalnızca FM2+ işlemci ile desteklenir. FM2 işlemciyle, yalnızca PCIE 2.0 destekler. - 2 x PCI Express 2.0 x1 yuva - AMD Dual Graphics'i destekler
Grafikler	<ul style="list-style-type: none"> - A serisi APU'da tümleşik AMD Radeon™ R7/R5 serisi grafikler - FM2+ işlemciyle DirectX 11.1, Pixel Shader 5.0. FM2 işlemciyle DirectX 11, Pixel Shader 5.0. - Maks. paylaşılan bellek 2GB - Бз VGA Зэкэю сезенепи: D-Sub, DVI-D ve HDMI - Üçlü Monitör Desteği - 24Hz'de 4K x 2K (4096x2160)'e kadar maks. зцзынрыкык HDMI Teknolojisini destekler * Sadece FM2 + APU HDMI portu üzerinden 4096x2160 çözünürlüklü ekrana kadar destekler - 60Hz'de 2560x1600'e kadar maks. зцзынрыкык Dual-link DVI-D'yə destekler - 60Hz'de 1920x1600'ya kadar maks. зцзынрыкык D-Sub'ə destekler - Auto Lip Sync, Deep Color (12bpc), HDMI ile xvYCC ve HBR'yi (Yüksek Bit Hızlı Ses) destekler (Uyumlu HDMI monitür gerekir) - HDMI bulunan Blu-Ray stereoskopik 3D'yi desteklemektedir - AMD Steady Video™ 2.0'yu destekler: Ev/çevrimiçi videoda otomatik titreşim azaltma için yeni video işleme sonrası özelliği - DVI-D ve HDMI portlarıyla HDCP июлевини destekler

	- DVI-D ve HDMI portlarıyla Tam HD 1080p Blu-ray (BD) oynatma desteği
Ses	- 5.1 CH HD Ses (Realtek ALC662 Ses Codec Bileşeni) - Dalgalanma Korumasını destekler (ASRock Tam Ani Yükseliş Koruması) - ELNA Audio Caps.
LAN	- PCIE x1 Gigabit LAN 10/100/1000 Mb/s - Realtek RTL8111GR - WAN üzerinden açma destekler - LAN Açılışını Destekler - Yıldırım/ESD Korumasını destekler (ASRock Tam Ani Yükseliş Koruması) - LAN Kablo Algılama'yı destekler - Enerji Verimliliğine Sahip Ethernet 802.3az işlevini destekler - PXE özelliğini destekler
Arka Panel G/3	- 1 x PS/2 Fare Bağlantı Noktası - 1 x PS/2 Klavye Bağlantı Noktası - 1 x D-Sub Portu - 1 x DVI-D Portu - 1 x HDMI Portu - 4 x Kullanıma Hazır USB 2.0 Portu (ESD Korumasını destekler (ASRock Tam Ani Yükseliş Koruması)) - 2 x Kullanıma Hazır USB 3.0 Portu (AMD A88X (Bolton-D4)) (ESD Korumasını destekler (ASRock Tam Ani Yükseliş Koruması)) - 1 x RJ-45 LAN Portu, LED'li (AKT/LÖNK LED'i ve HIZ LED) - HD Ses Jakı: Hat Girişi / Ön Hoparlör / Mikrofon
Depolama	- 8 x SATA3 6,0Gb/sn konektör, donanım RAID (RAID 0, RAID 1, RAID 5 ve RAID 10), NCQ, AHCI ve "Sistem Azekken Bileşen Takma" işlevlerini
Konektör	- 1 x Kasaya Yetkisiz Erişim fişi - 1 x TPM bağlantısı - 1 x CPU FAN konektörü (4 pin) - 1 x Kasa FAN konektörü (4 pin) - 1 x 24 pin ATX güç konektörü - 1 x 4 pin 12V güç konektörü - 1 x Ön panel ses konektörü - 2 x USB 2.0 fiş (4 USB 2.0 portu destekler) (ESD Korumasını destekler (ASRock Tam Ani Yükseliş Koruması)) - 1 x AMD A88X (Bolton-D4) ile USB 3.0 bağlantısı (2 USB 3.0 portu destekler) (ESD Korumasını destekler (ASRock Tam Ani Yükseliş Koruması))

BIOS Özelliği	<ul style="list-style-type: none"> - 64 Mb GUI destekli AMI UEFI Geçerli BIOS - GUI destekli AMI UEFI Geçerli BIOS - "Tak Çalıştır"ı destekler - ACPI 1.1 Uyumlu Uyandırma Olayları - Jumpersiz ayarlamayı destekler - AMBIOS 2.3.1 Desteği - DRAM ve CPU Voltaj Çoklu ayarı
Donanım Monitör	<ul style="list-style-type: none"> - CPU Sıcaklık Duyarlılığı - Kasa Sıcaklık Duyarlılığı - CPU Fan Takometresi - Kasa Fan Takometresi - CPU/Kasa Sessiz Fanı - CPU/Kasa Fan Çoklu-Hız Kontrolü - KASA AÇIK algılaması - Voltaj İzleme: +12V, +5V, +3,3V, CPU Vcore
İS	<ul style="list-style-type: none"> - Microsoft® Windows® 8.1 32-bit / 8.1 64-bit / 8 32-bit / 8 64-bit / 7 32-bit / 7 64-bit
Sertifikalar	<ul style="list-style-type: none"> - FCC, CE, WHQL - ErP/EuP Hazır (ErP/EuP hazır güç kaynağı gerekli)

* Ayrıntılı ürün bilgileri için lütfen web sitemizi ziyaret edin: <http://www.asrock.com>

1.3 Jumper'ların Ayarı

Şekilde jumper'ların nasıl ayarlandıkları gösterilmektedir. Jumper kapağı pinler üzerine yerleştirildiğinde jumper "Kapalı" dır. Jumper kapağı pinler üzerindeyken jumper "Açık" tır. Şekilde pin1 ve pin2'si "Kapalı" olan jumper kapağı bu 2 pine yerleştirilmiş 3-pinli jumper gösterilmektedir.

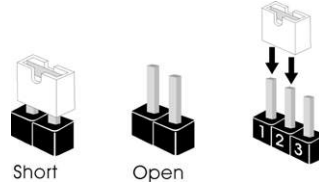

Jumper

Ayar

CMOS'u temizleme

(CLRCMOS1, 3-pinli jumper)

(bkz. S.2 No. 22)



Default



Clear CMOS

Not: CLRCMOS1, CMOS'daki verilerinizi temizlemenize olanak sağlar. Sistem parametrelerini temizlemek ve varsayılan ayara sıfırlamak için lütfen bilgisayarı kapatın ve güç kablosunun fişini güç kaynağından çekin. 15 saniye bekledikten sonra, pin2 ve pin3'ü CLRCMOS1'de 5 saniye kısaltmak için bir atlatici şapkası kullanın. Ancak, BIOS'u güncelledikten hemen sonra lütfen CMOS'u temizlemeyin. BIOS'u güncellemeyi tamamladığınızda CMOS'u temizlemeniz gerekirse, ilk olarak sistemi başlatmanız ve ardından CMOS temizleme işlemini gerçekleştirmeden önce kapatmanız gereklidir. Parola, tarih, saat, kullanıcı varsayılan profili, 1394 GUID ve MAC adresinin yalnızca CMOS pili çıkarıldığında temizleneceğini lütfen aklınızda bulundurunuz.



CMOS'u temizlerseniz, kasa açma algılanabilir. Lütfen "Temizleme Durumu" BIOS seçeneğini önceki kasaya yetkisiz erişim durumunun kaydı için ayarlayın.

1.4 Yerleşik Fişler ve Konektörler



Yerleşik fişler ve konektörler jumper DEĞİLDİR. Bu fişlerin ve konektörlerin üzerine jumper kapakları YERLEŞTİRMEYİN. Fişlerin ve konektörlerin üzerine jumper kapakları yerleştirmek anakartın kalıcı olarak zarar görmesine neden olabilir!

Seri ATA3 Konektörler

(SATA_1: bkz. S.2, No. 16)
 (SATA_2: bkz. S.2, No. 15)
 (SATA_3: bkz. S.2, No. 14)
 (SATA_4: bkz. S.2, No. 13)
 (SATA_5: bkz. S.2, No. 12)
 (SATA_6: bkz. S.2, No. 11)
 (SATA_7: bkz. S.2, No. 9)
 (SATA_8: bkz. S.2, No. 8)



Bu sekiz Seri ATA3 (SATA3) konektör, dahili depolama cihazları için SATA veri kablolarını destekler. Geçerli SATA3 arayüzü 6,0 Gb/sn veri aktarım hızına izin verir.

USB 2.0 Fişleri

(9-pinli USB_6_7)
 (bkz. S.2 No. 18)
 (9-pinli USB_8_9)
 (bkz. S.2 No. 19)

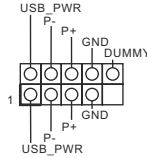

G/Ç panelindeki varsayılan dört USB 2.0 portundan başka, bu anakartta iki USB 2.0 fişi bulunur. Her USB 2.0 fişi iki USB 2.0 portunu destekler.

USB 3.0 Fişleri

(19-pinli USB_10_11)
 (bkz. S.2 No. 20)

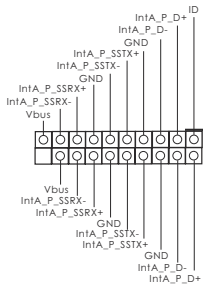

I/O panelinde bulunan iki adet varsayılan USB 3.0 bağlantı noktasının yanı sıra, bu ana kart üzerinde bir adet USB 3.0 bağlantısı bulunur. Bu USB 3.0 bağlantısı iki adet USB 3.0 bağlantı noktasını destekleyebilir.

Ön Panel Ses Fişi

(9-pinli HD_AUDIO1)

(bkz. S.2 No. 21)

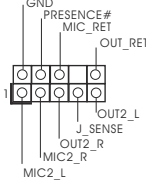

Bu, panel ses kablosu için uygun bağlantı sağlayan ve ses cihazlarını kontrol etmeyi sağlayan bir arayüzdür.



1. Yüksek Tanımlı Ses Jak Duyarlılığını destekler, ancak kasadaki panel kablosunun HDA'nın düzgün çalışmasını desteklemesi gerekir. Lütfen sisteminizi yüklemek için kılavuzumuzdaki ve kasa kılavuzundaki talimatları izleyin.
2. AC'97 ses paneli kullanıyorsanız, lütfen ön panel ses fişine aşağıdaki gibi takın:
 - A. Mic_IN'i (MIC) MIC2_L'ye bağlayın.
 - B. Audio_R'yi (RIN) OUT2_R'ye ve Audio_L'yi (LIN) OUT2_L'ye bağlayın.
 - C. Ground'u (GND) Ground'a (GND) bağlayın.
 - D. MIC_RET ve OUT_RET yalnızca HD ses paneli içindir. Bunları AC'97 ses paneli için bağlamanız gerekmez.
 - E. Ön mikrofonu etkinleştirmek için
Windows® 8.1 / 8.1 64-bit / 8 / 8 64-bit / 7 / 7 64-bit İS için:
Realtek Kontrol panelinde "Ön Mikrofon" Sekmesine gidin. "Kayıt Ses Seviyesi"ni ayarlayın.

Sistem Paneli Fişi

(9-pinli PANEL1)

(bkz. S.2 No. 17)

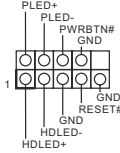

Bu fiş, birçok sistem ön paneli işlevini barındırır.



Kasa üzerindeki güç anahtarını, sıfırlama anahtarını ve sistem durumu göstergesini aşağıdaki pin atamalarına göre bu bağlantıya bağlayın. Kabloları bağlamadan önce pozitif ve negatif pinlere dikkat edin.

PWRBTN (Güç Anahtarı):

Kasa üzerindeki güç anahtarını ön panele bağlayın. Güç anahtarını kullanarak sisteminizi kapatma şeklinizi yapılandırabilirsiniz.

RESET (Sıfırlama Anahtarı):

Kasa üzerindeki sıfırlama anahtarını ön panele bağlayın. Bilgisayar donarsa veya normal bir yeniden başlatma gerçekleştirilemezse, bilgisayarı yeniden başlatmak için sıfırlama anahtarına basın.

PLED (Sistem Gücü LED'i):

Kasa üzerindeki güç durumu göstergesini ön panele bağlayın. Sistem çalışırken LED yanar. Sistem S1 uyku modunda iken LED yanıp sönmeye devam eder. Sistem S3/S4 uyku modunda veya kapalı (S5) iken LED söner.

HDLED (Sabit Disk Çalışma LED'i):

Kasa üzerindeki sabit disk çalışma LED'ini ön panele bağlayın. Sabit disk veri okurken veya yazarken LED yanar.

Ön panel tasarımı kasaya göre değişiklik gösterebilir. Ön panel modülünde temel olarak güç anahtarı, sıfırlama anahtarı, güç LED'i, sabit disk çalışma LED'i, hoparlör vb. bulunur. Kasa ön panel modülünüzü bu bağlantıya bağlarken, kablo atamalarının ve pin atamalarının doğru biçimde eşleştirildiğinden emin olun.

Kasa Hoparlörü Fişi

(4-pinli SPEAKER1)

(bkz. S.2 No. 7)



Lütfen kasa hoparlörünü bu fişe bağlayın.

Kasa Fan Konektörü

(4-pinli CHA_FAN1)

(bkz. S.2 No. 10)

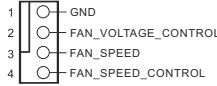

Lütfen kasa fan kablolarını fanına bu konektöre bağlayın ve siyah kabloyu toprak pinine bağlayın.

CPU Fan Konektörü

(4-pinli CPU_FAN1)

(bkz. S.2 No. 2)

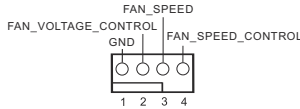

Lütfen fan kablolarını CPU fanına bu konektöre bağlayın ve siyah kabloyu toprak pinine bağlayın.



Bu anakart 4-Pinli CPU fan (Sessiz Fan) desteği sağlasa da, 3-Pinli CPU fan hızı kontrol işlevi olmadan bile hala başarılı bir şekilde çalışabilir. 3-Pinli CPU fanı bu konektördeki CPU fan konektörüne bağlamayı planlıyorsanız, lütfen Pin 1-3'e bağlayın.

Pin 1-3 Bağlı ←

3-Pinli Fanı Takma

**ATX Güç Konektörü**

(24-pinli ATXPWR1)

(bkz. S.2 No. 5)

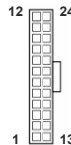

Lütfen bir ATX güç kaynağını bu konektöre bağlayın.



Bu anakart 24-pinli ATX güç konektörü sağlarsa da geleneksel bir 20-pinli ATX güç kaynağı bağlarsanız da çalışabilir. 20-pinli ATX güç kaynağını kullanmak için, lütfen güç kaynağınızı Pin 1 ve Pin 13'le birlikte takın.



20-Pinli ATX Güç Kaynağını Takma 1

ATX 12V Güç Konektörü

(4-pinli ATX12V1)

(bkz. S.2 No. 1)



Lütfen bir ATX 12V güç kaynağını bu konektöre bağlayın.

Kasaya Yetkisiz Erişim Fişi

(2-pinli C11)

(bkz. S.2 No. 23)



Bu anakart, kasa kapağının çıkarılıp çıkarılmadığını algılayan KASA AÇIK algılama özelliğini destekler. Bu özellik, kasaya yetkisiz erişim tasarımına sahip bir kasa gerektirir.

TPM Bağlantısı

(17-pinli TPMS1)

(bkz. s.2 No. 6)

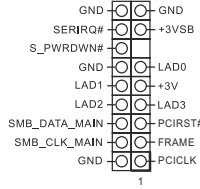

Bu bağlayıcı, anahtarlar, dijital sertifikalar, parolalar ve verileri güvenli bir şekilde saklama özelliği bulunan Güvenilir Platform Modülü (TPM) sistemini destekler. TPM sistemleri, aynı zamanda ağ güvenliğinin artırılması, dijital kimliklerin korunması ve platform bütünlüğünün sağlanmasına da yardımcıdır.

1. 제품소개

ASRock의 **FM2A88M Pro3+** 메인 보드를 구매하여 주신것에 대하여 감사 드립니다. 이 메인보드는 엄격한 품질관리 하에 생산되어진 신뢰성 있는 메인보드입니다. 이 제품은 고 품격 디자인과 함께 ASRock의 우수한 품질과 최고의 안정성을 자랑하고 있습니다. 이 빠른 설치 안내서에는 마더보드에 대한 설명과 단계별 설치 방법이 실려 있습니다. 마더보드에 대한 보다 자세한 내용은 지원 CD의 사용 설명서에서 확인할 수 있습니다.



메인보드의 사양이나 바이오스가 업데이트 되기 때문에 이 사용자 설명서의 내용은 예고 없이 변경되거나 바뀔 수가 있습니다. 만일을 생각해서 이 사용자 설명서의 어떤 변경이 있으면 ASRock의 웹사이트에서 언제든지 업데이트를 하실 수 있습니다. 웹사이트에서 최신 VGA 카드와 CPU 지원 목록을 확인할 수 있습니다. ASRock의 웹사이트 주소는 <http://www.asrock.com>입니다. 본 마더보드와 관련하여 기술 지원이 필요한 경우 당사 웹사이트를 방문하여 사용 중인 모델에 대한 특정 정보를 얻으십시오. www.asrock.com/support/index.asp

1.1 패키지 내용

ASRock **FM2A88M Pro3+** 마더보드 (Micro ATX 폼 팩터)
 ASRock **FM2A88M Pro3+** 쿼 설치 가이드
 ASRock **FM2A88M Pro3+** 지원 CD
 시리얼 ATA (SATA) 데이터 케이블 2개 (선택 사양)
 I/O 차폐 1개

1.2 설명서

플랫폼	<ul style="list-style-type: none"> - Micro ATX 폼 팩터 - 모든 솔리드 콘덴서 구조 - 고 밀도 유리 직물 PCB
CPU	- 소켓 FM2+ 95W / FM2 100W 프로세서에 대한 지원
칩셋	- AMD A88X (Bolton-D4)
메모리	<ul style="list-style-type: none"> - 듀얼 채널 메모리 기술 지원 - DDR3 DIMM 슬롯 4 개 - DDR3 2400+(OC)/2133/1866/1600/1333/1066 비 -ECC, 언버퍼드 메모리를 지원 - 최대 시스템 메모리 용량 : 64GB - Intel® 익스트림 메모리 프로파일 (XMP) 1.3/1.2 지원 - 최대 AMP 2400 의 AMD 메모리 프로파일 기술 (AMP) 지원
확장 슬롯	<ul style="list-style-type: none"> - 1 x PCI Express 3.0 x16 슬롯 (PCIE1: x16 모드) * PCIE 3.0 은 FM2+ CPU 에서만 지원됩니다 . FM2 CPU 의 경우 PCIE 2.0 만 지원합니다 . - 2 개의 PCI Express 2.0 x1 슬롯 - AMD 듀얼 그래픽 지원
온보드 VGA	<ul style="list-style-type: none"> - A 시리즈 APU 에 통합된 AMD Radeon™ R7/R5 시리즈 그래픽 - FM2+ CPU 의 경우 DirectX 11.1, Pixel Shader 5.0 탑재 . - FM2 CPU 의 경우 DirectX 11, Pixel Shader 5.0 탑재 . - 최대 공유 메모리 2GB - 3 개의 VGA 출력 옵션 : D-Sub, DVI-D 및 HDMI - 삼중 모니터 지원 - 최대 해상도 4K x 2K (4096x2160) @ 24Hz 까지 HDMI 지원 * HDMI 를 통한 4096x2160 해상도 출력은 FM2+ APU 에서만 지원됩니다 . - 최대 해상도 2560x1600 @ 60Hz 까지 Dual-link DVI-D 지원 - 최대 해상도 1920x1200 @ 60Hz 까지 D-Sub 지원 - 자동 립 싱크 (Auto Lip Sync), 딥 컬러 (Deep Color)(12bpc), xvYCC, HBR (고비트율 오디오), HDMI 지원 (HDMI 호환 모니터 필요) - HDMI 로 블루레이 스테레오스코픽 3D 를 지원합니다 - AMD Steady Video™ 2.0 지원 : 홈 / 온라인 비디오의 자동 떨림감소를 위한 새로운 비디오 포스트 프로세싱 능력 - DVI-D 및 HDMI 포트를 이용한 HDCP 기능 지원 - DVI-D 및 HDMI 포트를 이용한 1080p Blu-ray (BD) 지원

오디오	<ul style="list-style-type: none"> - 5.1 CH HD 오디오 지원 (Realtek ALC662 오디오 코덱) - 서지 보호 지원 (ASRock 폴 스파이크 보호) - ELNA Audio Caps.
랜	<ul style="list-style-type: none"> - PCIE 1 개, Gigabit LAN 10/100/1000 Mb/s - Realtek RTL8111GR - Wake-On-WAN 지원 - 조명 /ESD 보호 (ASRock 폴 스파이크 보호) 지원 - LAN 케이블 감지 지원 - 절전형 이더넷 802.3az 지원 - PXE 지원
후면판 I/O	<ul style="list-style-type: none"> - 1 개 PS/2 마우스 포트 - 1 개 PS/2 키보드 포트 - 1 개의 D-Sub 포트 - 1 개의 DVI-D 포트 - 1 개의 HDMI 포트 - 4 개디포트 USB 2.0 포트 (ESD 보호 지원 (ASRock 폴 스파이크 보호)) - 2 개디포트 USB 3.0 포트 (AMD A88X (Bolton-D4)) (ESD 보호 지원 (ASRock 폴 스파이크 보호)) - 1 개 LED(ACT/LINK LED 및 SPEED LED) 가 있는 RJ-45 LAN 포트 - 오디오 잭 : 라인 인 / 전방 스피커 / 마이크
저장 장치	<ul style="list-style-type: none"> - 8 개 의 SATA3 6.0Gb/s 커넥터, RAID (RAID 0, RAID 1, RAID5 및 RAID 10), NCQ, AHCI 및 “ 핫 플러그 ” 기능 지원
온보드 헤더 및 커넥터	<ul style="list-style-type: none"> - 새시 침입 헤더 1 개 - TPM 헤더 1 개 - CPU 팬 커넥터 1 개 (4 핀) - 새시 팬 커넥터 1 개 (4 핀) - 24 핀 ATX 전원 헤더 1 개 - 4 핀 ATX 12V 파워 콘넥터 1 개 - 전면부 오디오 콘넥터 1 개 - USB 2.0 헤더 2 개 (USB 2.0 포트 4 개 지원) (ESD 보호 지원 (ASRock 폴 스파이크 보호)) - AMD A88X (Bolton-D4) 의 USB 3.0 헤더 1 개 (USB 3.0 포트 2 개 지원) (ESD 보호 지원 (ASRock 폴 스파이크 보호))
BIOS	<ul style="list-style-type: none"> - 64Mb GUI 지원을 제공하는 AMI UEFI 적합형 BIOS - “플러그 앤 플레이” 지원 - ACPI 1.1 웨이크 - 업 이벤트와의 호환 - 점퍼 프리 지원 - 점퍼 프리 지원 ; SMBIOS 2.3.1 지원 - DRAM 및 CPU 전압 멀티조정

하드웨어 모니터	<ul style="list-style-type: none"> - CPU 온도 감지 - 새시 온도 감지 - CPU 팬 회전속도계 - 새시 팬 회전속도계 - CPU/ 새시 저소음 팬 - CPU/ 새시 팬 다중 속도 제어 - 케이스 열림 감지 - 전압 감시 기능 : +12V, +5V, +3.3V, Vcore
OS	- 마이크로 소프트 Windows® 8.1 32 비트 / 8.1 64 비트 / 8 32 비트 / 8 64 비트 / 7 32 비트 / 7 64 비트
인증서	<ul style="list-style-type: none"> - FCC, CE, WHQL - ErP/EuP 지원 (ErP/EuP 지원 전원 공급기가 요구됨)

* 상세한 제품정보는 당사의 웹사이트를 방문할수있습니다 . <http://www.asrock.com>

1.4 온보드 헤더 및 커넥터



주의!

이 콘넥터는 접퍼가 아닙니다. 이 콘넥터 위에 접퍼 캡을 사용하지 마세요. 콘넥터에 접퍼 캡을 설치하면 마더보드가 영구적으로 손상됩니다!

시리얼 ATA3 커넥터

- (SATA_1: 2 페이지, 16 번 항목 참조)
- (SATA_2: 2 페이지, 15 번 항목 참조)
- (SATA_3: 2 페이지, 14 번 항목 참조)
- (SATA_4: 2 페이지, 13 번 항목 참조)
- (SATA_5: 2 페이지, 12 번 항목 참조)
- (SATA_6: 2 페이지, 11 번 항목 참조)
- (SATA_7: 2 페이지, 9 번 항목 참조)
- (SATA_8: 2 페이지, 8 번 항목 참조)



8 개의 시리얼 ATA3

(SATA3) 커넥터는 내부 저장 장치용 SATA 데이터 케이블을 지원합니다. 커넥터가 내부 기억 장치용 SATA 케이블을 지원합니다. 현재의 SATA3 인터페이스는 최고 6.0 Gb/s 의 데이터 전송 속도를 지원합니다.



USB 2.0 헤더

- (9 편 USB_6_7)
- (2 페이지, 18 번 항목 참조)
- (9 편 USB_8_9)
- (2 페이지, 19 번 항목 참조)

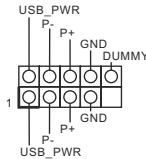

본 마더보드에는 I/O 패널에 있는 4 개의 기본 USB 2.0 포트 외에도 USB 2.0 헤더가 2 개 있습니다. 각각의 USB 2.0 헤더는 2 개의 USB 2.0 포트를 지원할 수 있습니다.

USB 3.0 헤더

- (19 편 USB_10_11)
- (2 페이지, 20 번 항목 참조)

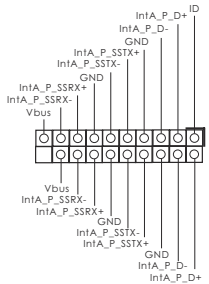

I/O 패널에 있는 2 개의 기본적 USB 3.0 포트 이외에도 마더보드에 1 개의 USB 3.0 헤더가 있습니다. 이 USB 3.0 헤더는 2 개의 USB 3.0 포트를 지원할 수 있습니다.

전면부 오디오 콘넥터

(9 편 HD_AUDIO1)

(2 페이지, 21 번 항목 참조)

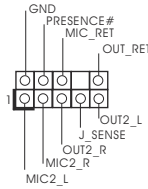

이 콘넥터는 오디오 장치를 편리하게 조절하고 연결할 수 있는 전면 오디오 인터페이스입니다.



1. High Definition Audio (고음질 오디오)는 잭 센스 기능을 지원하나, 제대로 작동하려면 새시의 패널 와이어가 HAD를 지원해야 합니다. 이 설명서 및 새시 설명서의 지침을 따라 시스템을 설치하십시오.
2. AC' 97 오디오 패널을 사용하는 경우, 이를 아래와 같이 프론트 패널의 오디오헤더에 설치하십시오.
 - A. Mic_IN (MIC)을 MIC2_L에 연결합니다.
 - B. Audio_R (RIN)을 OUT2_R에 연결하고, Audio_L (LIN)을 OUT2_L에 연결합니다.
 - C. Ground (GND)을 Ground (GND)에 연결합니다.
 - D. MIC_RET 및 OUT_RET는 HD 오디오 패널 전용입니다. 이들을 AC' 97 오디오 패널에 연결하지 않아도 됩니다.
 - E. 앞면 마이크 작동.
Windows® 8.1 / 8.1 64 비트 / 8 / 8 64 비트 / 7 / 7 64 비트 OS의 경우:
Realtek 제어판에서 "FrontMic" (앞면 마이크)로 가서 "Recording Volume" (리코딩 볼륨)을 조정합니다.

시스템 콘넥터

(9 편 PANEL1)

(2 페이지, 17 번 항목 참조)

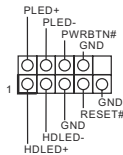

이 콘넥터는 시스템 전면 패널 기능을 지원하기 위한 것입니다.



새시의 전원 스위치, 리셋 스위치, 시스템 상태 표시등을 아래의 핀 할당에 따라 이헤더에 연결합니다. 케이블을 연결하기 전에 양극 핀과 음극 핀을 기록합니다.

PWRBTN(전원 스위치):

새시 전면 패널의 전원 스위치에 연결합니다. 전원 스위치를 이용해 시스템을 끄는방법을 구성할 수 있습니다.

RESET(리셋 스위치):

새시 전면 패널의 리셋 스위치에 연결합니다. 컴퓨터가 정지하고 정상적 재시작을수행하지 못할 경우 리셋 스위치를 눌러 컴퓨터를 재시작합니다.

고
성
하

PLED(시스템 전원 LED):

새시 전면 패널의 전원 상태 표시등에 연결합니다. 시스템이 작동하고 있을 때는 LED가 켜져 있습니다. 시스템이 S1 대기 상태에 있을 때는 LED가 계속 깜박입니다. 시스템이 S3/S4 대기 상태 또는 전원 꺼짐 (S5) 상태에 있을 때는 LED가 꺼져 있습니다.

HDLED(하드 드라이브 동작 LED):

새시 전면 패널의 하드 드라이브 동작 LED에 연결합니다. 하드 드라이브가 데이터를 읽거나 쓰고 있을 때 LED가 켜져 있습니다.

전면 패널 디자인은 새시별로 다를 수 있습니다. 전면 패널 모듈은 주로 전원 스위치, 리셋 스위치, 전원 LED, 하드 드라이브 동작 LED, 스피커 등으로 구성되어 있습니다. 새시 전면 패널 모듈을 이 헤더에 연결할 때 와이어 할당과 핀 할당이 정확히 일치하는지 확인합니다.

새시 스피커 헤더

(4 핀 SPEAKER1)
(2 페이지, 7 번 항목 참조)

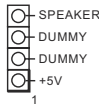

새시 스피커를 이 헤더에 연결하십시오.

새시 팬 커넥터

(4 핀 CHA_FAN1)
(2 페이지, 10 번 항목 참조)

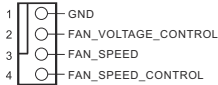

팬 케이블을 팬 커넥터에 연결하고 접지 핀에는 검은색 전선을 연결하십시오.

CPU 팬 커넥터

(4 핀 CPU_FAN1)
(2 페이지, 2 번 항목 참조)

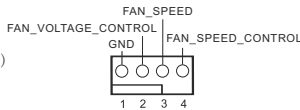

CPU 팬 케이블을 이 커넥터에 연결하고 흑색 선을 접지 핀에 맞추십시오.



본 머더보드가 4 핀 CPU 팬 (저소음 팬) 지원을 제공하지는 않지만 팬 속도 제어기능없어도 3 핀 CPU 팬을 성공적으로 작동할 수 있습니다. 본 머더보드의 CPU 팬 커넥터에 3 핀 CPU 팬을 연결하려면 1-3 번 핀에 연결하십시오.

1-3 번 핀에 연결됨 ←

3 핀 팬 설치



ATX 전원 헤더

(24 핀 ATXPWR1)
(2 페이지, 5 번 항목 참조)

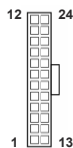

ATX 전원 공급기를 이 헤더에 연결하십시오.



이 마더보드는 24 핀 ATX 전원 커넥터를 제공하지만, 종래의 20 핀 ATX 전원 공급장치를 사용해도 작동이 가능합니다. 20 핀 ATX 전원 공급장치를 사용하려면, Pin 1 과 Pin 13 으로 전원공급장치를 연결하십시오.



20 핀 ATX 전원 공급장치 설치



ATX 12V 파워 콘넥터

(4 핀 ATX12V1)

(2 페이지, 1 번 항목 참조)



ATX 12V 플러그가 달린 전원공급장치를 이 커넥터에 연결해야 충분한 전력을 공급할 수 있습니다. 그러지 않을 경우 전원을 켤 수 없습니다.

새시 침입 헤더

(2 핀 CI1)

(2 페이지, 23 번 항목 참조)



이 메인보드는 새시 커버가 제거되면 이를 감지하는 케이스 열림 감지 기능을 지원합니다. 이 기능은 새시에 새시 침입 감지 디자인이 있어야 가능합니다.

TPM 헤더

(17 핀 TPMS1)

(2 페이지, 6 번 항목 참조)

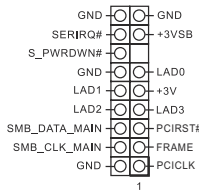

이 커넥터는 키, 디지털 인증서, 암호 및 데이터를 안전하게 보관할 수 있는 TPM(Trusted Platform Module) 시스템을 지원합니다. TPM 시스템은 네트워크 보안을 강화하고, 디지털 신원을 보호하며 플랫폼 무결성을 유지합니다.

고
성
하

1. はじめに

ASRock **FM2A88M Pro3+** マザーボードをお買い上げいただきありがとうございます。本製品は、弊社の厳しい品質管理の下で製作されたマザーボードです。本製品は、弊社の品質と耐久性の両立という目標に適合した堅牢な設計により優れた性能を実現します。このクイックインストールガイドには、マザーボードの説明および段階的に説明したインストールの手引きが含まれています。マザーボードに関するさらに詳しい情報は、「サポート CD」のユーザーマニュアルを参照してください。



マザーボードの仕様および BIOS ソフトウェアは、アップデートされることがありますので、マニュアルの内容は、予告なしに変更されることがあります。本マニュアルに変更があった場合は、弊社のウェブサイトへ通告なしに最新版のマニュアルが掲載されます。最新の VGA カードおよび CPU サポートリストもウェブサイトでご覧になれます。ASRock 社ウェブサイト：
<http://www.asrock.com>

このマザーボードに関連する技術サポートが必要な場合、当社の Web サイトにアクセスし、使用しているモデルについての特定情報を見つけてください。
www.asrock.com/support/index.asp

1.1 パッケージ内容

ASRock **FM2A88M Pro3+** マザーボード (Micro ATX フォームファクター)

ASRock **FM2A88M Pro3+** クイックインストールガイド

ASRock **FM2A88M Pro3+** サポート CD

2 x シリアル ATA (SATA) データケーブル (オプション)

1 x I/O パネルシールド

1.2 仕様

プラットフォーム	<ul style="list-style-type: none"> - Micro ATX フォームファクター - オール固体コンデンサー設計 - 高密度ガラス繊維 PCB
CPU	<ul style="list-style-type: none"> - Socket FM2+ 95W / FM2 100W プロセッサのサポート
チップセット	<ul style="list-style-type: none"> - AMD A88X (Bolton-D4)
メモリー	<ul style="list-style-type: none"> - デュアルチャンネル DDR3 メモリーテクノロジー - DDR3 DIMM スロット x 4 - DDR3 2400+(OC)/2133/1866/1600/1333/1066 non-ECC, un-buffered メモリーに対応 - システムメモリの最大容量: 64GB - Intel® Extreme Memory Profile (XMP)1.3/1.2 をサポート - 最大 AMP 2400 までの AMD メモリプロファイルテクノロジー (AMP)に対応
拡張スロット	<ul style="list-style-type: none"> - 1 x PCI Express 3.0 x16 スロット (PCIe1: x16 モード) <li style="padding-left: 20px;">* PCIe 3.0 は FM2+ CPU でのみサポートされます。FM2 CPU では、PCIe 2.0 のみをサポートします。 - 2 x PCI Express 2.0 x1 スロット - AMD Dual Graphics に対応
グラフィック	<ul style="list-style-type: none"> - A シリーズ APU に統合された AMD Radeon™ R7/R5 シリーズグラフィックス - FM2+ CPU を搭載した DirectX 11.1, Pixel Shader 5.0。 - FM2 CPU を搭載した DirectX 11, Pixel Shader 5.0。 - 最大の共有メモリ 2GB - 3 つの VGA 出力オプション :D-Sub, DVI-D, HDMI - 3 台のモニターをサポート - 4K x 2K (4096x2160) @ 24Hz の最大解像度で HDMI をサポート <li style="padding-left: 20px;">* HDMI ポート経由で最大 4096x2160 の解像度ディスプレイに対応できるのは FM2+ APU だけです - 2560x1600 @ 60Hz の最大解像度で Dual-link DVI-D をサポート - 1920x1200 @ 60Hz の最大解像度で D-Sub をサポート - オート・リップシンク、ディープカラー(12bpc)、xvYCC、HBR(High Bit Rate)オーディオ、HDMI (HDMI 準拠モニターが必要)をサポート - HDMI 搭載 Blu-ray Stereoscopic 3D 対応 - AMD Steady Video™ 2.0 のサポート: 家庭 / オンラインビデオの自動ジッター低減用の新しいビデオポストの処理機能

	<ul style="list-style-type: none"> - HDCP 機能、DVI-D ポートおよび HDMI ポートをサポート - 1080p Blu-ray (BD) 再生サポート、DVI-D ポートおよび HDMI ポートをサポート
オーディオ	<ul style="list-style-type: none"> - 5.1 CH HD オーディオ(Realtek ALC662 オーディオコーデック) - サージ保護に対応(ASRock 完全スパイク保護) - ELNA Audio Caps.
LAN	<ul style="list-style-type: none"> - PCIE x1 ギガビット LAN 10/100/1000 Mb/ 秒 - Realtek RTL8111GR - ウェイクオン WAN をサポートします - ウェイクオンランをサポート - 雷 /ESD 保護((ASRock フルスバイク保護)をサポートします - LAN ケーブル検出をサポート - エネルギー効率のよいイーサネット 802.3az をサポート - PXE をサポート
リアパネル I/O	<ul style="list-style-type: none"> - PS/2 マウスポート x 1 - PS/2 キーボードポート x 1 - D-Sub ポート x 1 - DVI-D ポート x 1 - HDMI ポート x 1 - Ready-to-Use USB 2.0 ポート x 4 (ESD 保護(ASRock フルスバイク保護)をサポートします) - Ready-to-Use USB 3.0 ポート x 2 (AMD A88X (Bolton-D4)) (ESD 保護(ASRock フルスバイク保護)をサポートします) - LED(ACT/LINK LED および SPEED LED)付き - RJ-45 LAN ポート x 1 - オーディオジャック: 入力、前部スピーカー、マイク入力
ストレージ	<ul style="list-style-type: none"> - 8 x SATA3 6.0Gb/ 秒コネクタが、RAID (RAID 0、RAID 1、RAID 5 および RAID 10)、NCQ、AHCI および “Hot Plug” (ホットプラグ) 機能をサポート
コネクタ	<ul style="list-style-type: none"> - シャーシ侵入ヘッダ x 1 - TPM ヘッダー x 1 - CPU ファンコネクタ x 1 (4ピン) - シャーシファンコネクタ x 1 (4ピン) - 24ピン ATX 電源コネクタ x 1 - 4ピン 12V 電源コネクタ x 1 - フロントパネルオーディオコネクタ x 1 - USB 2.0 ヘッダー (USB 2.0 用 4ポートをサポート) x 2 (ESD 保護(ASRock フルスバイク保護)をサポートします) - AMD A88X (Bolton-D4) の USB 3.0 ヘッダー (USB 3.0 用 2ポートをサポート) x 1 (ESD 保護(ASRock フルスバイク保護)をサポートします)

BIOS 関連機能	<ul style="list-style-type: none"> - 64Mb AMI UEFI Legal BIOS(GUI サポート)き - プラグ&プレイをサポート - ACPI 1.1 準拠ウェイクアップイベント - jumperfree モードサポート - SMBIOS 2.3.1 サポート - DRAM および CPU ブリッジ電圧
モニター	<ul style="list-style-type: none"> - CPU 温度検知 - マザーボード温度検知 - CPU ファンタコメータ - シャーシファンタコメータ - CPU/ シャーシ静音ファン - CPU/ シャーシファンマルチ速度制御 - ケースオープン検出 - 電源モニター: +12V, +5V, +3.3V, Vcore
OS	<ul style="list-style-type: none"> - Microsoft® Windows® 8.1 32-bit / 8.1 64-bit / 8 32-bit / 8 64-bit / 7 32-bit / 7 64-bit
認証	<ul style="list-style-type: none"> - FCC, CE, Microsoft® WHQL 認証済み - ErP/EuP 対応(ErP/EuP 対応の電源装置が必要です)

* 製品の詳細については、<http://www.asrock.com> を御覧ください。

1.3 ジャンパ設定

右の図はジャンパがどのように設定されているかを示します。ジャンパキャップがピンに置かれている場合、ジャンパは“ショート”になります。ジャンパキャップがピンに置かれていない場合、ジャンパは“オープン”になります。右の図で、3ピンジャンパで、1-2ピンを“ショート”の場合、これらの2つのピンにジャンパキャップを置きます。

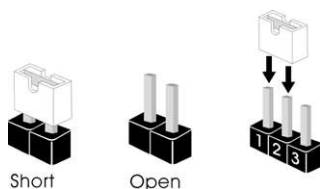

ジャンパ	設定	説明
CMOSの消去ジャンパ (CLRCMOS1) (ページ2アイテム22参照)	 1_2 デフォルト設定	 2_3 CMOSの消去

注： CLRCMOS1により、CMOSのデータをクリアできます。システムパラメータをクリアしデフォルト設定にリセットするには、コンピュータの電源をオフにし、電源装置から電源コードを抜いてください。15秒待ってから、ジャンパキャップを使用してCLRCMOS1のピン2とピン3を5秒間ショートしてください。ただし、BIOS更新の後すぐにはCMOSをクリアしないでください。BIOS更新の終了後直ちにCMOSをクリアする必要がある場合、まずシステムを起動してからシャットダウンし、その後クリアCMOSアクションを実行する必要があります。パスワード、日付、時刻、ユーザーデフォルトのプロファイルを忘れずにメモしてください。1394 GUIDとMACアドレスは、CMOSバッテリーを取り外した場合のみ消去されます。



CMOSをクリアすると、ケースオープンが検出されることがあります。BIOSオプションの「Clear Status」(ステータスのクリア)を変更して、直前のシャーン・イントルージョン・ステータスの記録を消去してください。

1.4 オンボードのヘッダとコネクタ類



オンボードのヘッダとコネクタ類はジャンパではありません。それらのヘッダやコネクタにジャンパキャップをかぶせないでください。ヘッダやコネクタにジャンパキャップをかぶせると、マザーボードに深刻な影響を与える場合があります。

シリアル ATA3 コネクタ

SATA_1: ページ 2, アイテム 16 を参照
 SATA_2: ページ 2, アイテム 15 を参照
 SATA_3: ページ 2, アイテム 14 を参照
 SATA_4: ページ 2, アイテム 13 を参照
 SATA_5: ページ 2, アイテム 12 を参照
 SATA_6: ページ 2, アイテム 11 を参照
 SATA_7: ページ 2, アイテム 9 を参照
 SATA_8: ページ 2, アイテム 8 を参照



これら 8 本のシリアル ATA3 (SATA3)コネクタは内蔵ストレージデバイスに使用する SATA データケーブルに対応しています。現在の SATA3 インタフェースの最大データ転送速度は 6.0 Gb/s です。

USB 2.0 ヘッダ

(9ピン USB_6_7)

ページ 2, アイテム 18 を参照

(9ピン USB_8_9)

ページ 2, アイテム 19 を参照

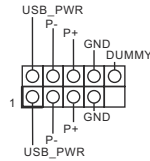

I/O パネルには、デフォルトの 4 つの USB 2.0 ポート以外に、このマザーボードに 2 つの USB 2.0 ヘッダが搭載されています。それぞれの USB 2.0 ヘッダは 2 つの USB 2.0 ポートをサポートできません。

USB 3.0 ヘッダ

(19ピン USB_10_11)

ページ 2, アイテム 20 を参照

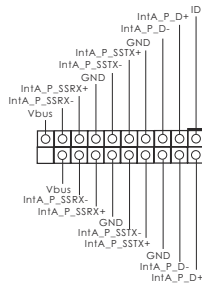

I/O パネルには、デフォルトの 2 つの USB 3.0 ポート以外に、このマザーボードに 1 つの USB 3.0 ヘッダが搭載されています。それぞれの USB 3.0 ヘッダは 2 つの USB 3.0 ポートをサポートできます。

フロントオーディオパネルコネクタ
(9ピン HD_AUDI01)
ページ 2, アイテム 21 を参照

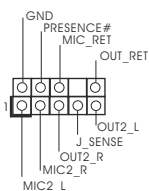

このコネクタは、オーディオ機器との便利な接続とコントロールを可能にするフロントオーディオパネルのためのインターフェイスです。



1. ハイディフィニションオーディオはジャックセンシングをサポートしますが、正しく機能するためにシャーシのパネルワイヤがHADをサポートする必要があります。このマニュアルとシャーシのマニュアルの指示に従って、システムを取り付けてください。
2. AC'97 オーディオパネルを使用する場合、次のように前面パネルのオーディオヘッダに取り付けてください。
 - A. Mic_IN (MIC) を MIC2_L に接続します。
 - B. Audio_R (RIN) を OUT2_R に、Audio_L (LIN) を OUT2_L に接続します。
 - C. Ground (GND) を Ground (GND) に接続します。
 - D. MIC_RET と OUT_RET はオーディオパネル専用です。AC'97 オーディオパネルに接続する必要はありません。
 - E. フロントマイクを有効化するには。
Windows® 8.1 / 8.1 64-bit / 8 / 8 64-bit / 7 / 7 64-bit OS の場合：
Realtek コントロールパネルから“FrontMic” (フロントマイク) タブを開きます。“Recording Volume”(録音音量) を調整します。

システムパネルコネクタ
(9ピン PANEL1)
ページ 2, アイテム 17 を参照

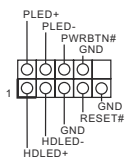

このコネクタは数種類のシステムフロントパネルの機能を提供します。



シャーシに付いている電源スイッチ、リセットスイッチ、システムステータスインジケータを下記のピン割り当て指示に従ってこのヘッダに接続します。ケーブルを接続する前にピンの正負極性にご注意ください。

PWRBTN (電源スイッチ):

前面パネルに付いている電源スイッチに接続します。電源スイッチによるシステム電源オフ方法を設定して変更することも可能です。

RESET (リセットスイッチ):

シャーシの前面パネルに付いているリセットスイッチに接続します。コンピュータがフリーズし、正常な再起動をしない場合は、リセットスイッチを押してコンピュータを再起動します。

PLED (システム電源 LED):

シャーシの前面パネルに付いている電源ステータスインジケータに接続します。LED は、システムが動作しているときに点灯します。LED はシステムが S1 スリープ状態のときに点滅します。システムが S3 または S4 スリープ状態になるか、電源オフ (S5) になると、LED は消灯します。

HDLED (ハードドライブアクティビティ LED):

シャーシの前面パネルに付いているハードドライブアクティビティ LED に接続します。LED は、ハードドライブがデータの読み込みまたは書き込み動作をしているときに点灯します。

前面パネルのデザインはシャーシによって異なります。前面パネルモジュールは、主に電源スイッチ、リセットスイッチ、電源 LED、ハードドライブアクティビティ LED、スピーカーなどから構成されています。シャーシの前面パネルモジュールをこのヘッダに接続する際は、ワイヤとピンの割り当てが正しく対応していることを確認してください。

シャーシスピーカーヘッダ

(4 ピン SPEAKER1)

ページ 2, アイテム 7 を参照

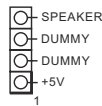

シャーシのスピーカーとこのヘッダを接続してください。

シャーシファンコネクタ

(4 ピン CHA_FAN1)

ページ 2, アイテム 10 を参照

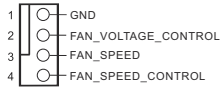

ファンケーブルをファンコネクタに接続し、黒いワイヤをアースピンに合わせてください。

CPU ファンコネクタ

(4 ピン CPU_FAN1)

ページ 2, アイテム 2 を参照

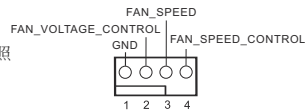

このコネクタには CPU ファンケーブルを接続します。黒いコードはアースピンに接続してください。



このマザーボードでは 4 ピン CPU ファン (クワイエットファン) がサポートされていますが、ファン速度コントロール機能がない場合でも、3 ピン CPU ファンは正常に作動します。3 ピン CPU ファンをこのマザーボードの CPU ファンコネクタに接続しようとしている場合、ピン 1-3 に接続してください。

接続されたピン 1-3 ←
3 ピンファンのインストール



ATX パワーコネクタ

(24ピン ATXPWR1)

ページ 2, アイテム 5 を参照

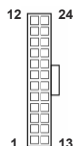

ATX 電源コネクタを接続します。



このマザーボードには 24 ピン ATX 電源コネクタが装備されており、従来の 20 ピン ATX 電源装置を採用している場合でも作動します。20 ピン ATX 電源を使用するには、ピン 1 およびピン 13 と共に電源装置にプラグを差し込みます。



20 ピン ATX 電源装置の取り付け

ATX 12V コネクタ

(4ピン ATX12V1)

ページ 2, アイテム 1 を参照



このコネクタには CPU に Vcore 電源を供給できるように、ATX 12V プラグを備えたサワーサプライを接続する必要があることに注意してください。接続に問題があると、電源は正しく供給されません。

ケース侵入ヘッダ

(2ピン C11)

ページ 2, アイテム 23 を参照



このマザーボードはケースオープン 信号検出機能に対応しており、シャーシカバーが取り外されているかどうかを検出します。この機能は、シャーシ侵入検出設計を組み込んだシャーシを必要とします。

TPM ヘッダー

(17ピン TPMS1)

ページ 2, アイテム 6 を参照

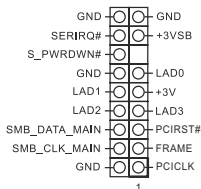

このコネクタはトラステッドプラットフォームモジュール (TPM) システムをサポートし、鍵、デジタル証明書、パスワード、データを安全に保管することができます。TPM システムはまた、ネットワークセキュリティを高め、デジタル証明書を保護し、プラットフォームの完全性を保証します。

1. 主板简介

谢谢你采用了华擎 **FM2A88M Pro3+** 主板，本主板由华擎严格制造，质量可靠，稳定性好，能够获得卓越的性能。本安装指南介绍了安装主板的步骤。更加详细的主板信息可参看驱动光盘的用户手册。



由于主板规格和 BIOS 软件将不断升级，本手册之相关内容变更恕不另行通知。请留意华擎网站上公布的升级版本。你也可以在华擎网站找到最新的显卡和 CPU 支持表。

华擎网址: <http://www.asrock.com>

如果您需要与此主板有关的技术支持，请参观我们的网站以了解您使用机种的规格信息。

www.asrock.com/support/index.asp

1.1 包装盒内物品

华擎 **FM2A88M Pro3+** 主板 (Micro ATX 规格)

华擎 **FM2A88M Pro3+** 快速安装指南

华擎 **FM2A88M Pro3+** 支持光盘

两条 Serial ATA(SATA) 数据线 (选配)

一块 I/O 挡板

1.2 主板规格

架构	<ul style="list-style-type: none"> - Micro ATX 规格 - 固态电容器设计 - 高密度防潮纤维电路板
处理器	<ul style="list-style-type: none"> - 支持 Socket FM2+ 95W / FM2 100W 处理器
芯片组	<ul style="list-style-type: none"> - AMD A88X (Bolton-D4)
系统内存	<ul style="list-style-type: none"> - 支持双通道 DDR3 内存技术 - 配备 4 个 DDR3 DIMM 插槽 - 支持 DDR3 2400+(超频)/2133/1866/1600/1333/1066 non-ECC、un-buffered 内存 - 最高支持 64GB 系统容量 - 支持 Intel® Extreme Memory Profile(XMP)1.3/1.2 - 支持最高 AMP 2400 的 AMD Memory Profile(AMP) 技术
扩展插槽	<ul style="list-style-type: none"> - 1 x PCI Express 3.0 x16 插槽 (PCIe1: x16 模式) <li style="padding-left: 20px;">* 仅 FM2+ CPU 支持 PCIe 3.0。对于 FM2 CPU, 只支持 PCIe 2.0。 - 2 x PCI Express 2.0 x1 插槽 - 支持 AMD 双显卡技术
板载显卡	<ul style="list-style-type: none"> - A 系列 APU 上集成 AMD Radeon™ R7/R5 显示核心 - DirectX 11.1、Pixel Shader 5.0 (FM2+ CPU)。 - DirectX 11、Pixel Shader 5.0 (FM2 CPU)。 - 最大共享内存 2GB - 支持三个 VGA 输出选项 :D-Sub、DVI-D 和 HDMI - 支持三显示器 - 支持 HDMI, 最高分辨率达 4K x 2K (4096x2160) @ 24Hz <li style="padding-left: 20px;">* 只有 FM2+ APU 可以通过 HDMI 端口支持高达 4096×2160 分辨率的显示器 - 支持 Dual-link DVI-D, 最高分辨率达 2560x1600 @ 60Hz - 支持 D-Sub, 最高分辨率达 1920x1200 @ 60Hz - 支持 HDMI, 可支持 Auto Lip Sync、Deep Color (12bpc)、xvYCC 与 HBR(高位速音频)(需配备兼容 HDMI 的显示器) - 支持蓝光立体 3D 和 HDMI - 支持 AMD Steady Video™ 2.0: 最新视频后处理能力, 可为家庭 / 在线视频提供自动降低抖动的功能 - 通过 DVI-D 和 HDMI 接口支持 HDCP 功能 - 通过 DVI-D 和 HDMI 接口可播放 1080 线蓝光光盘 (BD)
音效	<ul style="list-style-type: none"> - 5.1 CH 高清音频 (Realtek ALC662 音频编解码器) - 支持防突波 (华擎安全防护) - ELNA 专业音效电容

板载 LAN 功能	<ul style="list-style-type: none"> - PCIE x1 Gigabit LAN 10/100/1000 Mb/s - Realtek RTL8111GR - 支持 Wake-On-WAN (远端开机) - 支持 Wake-On-LAN (网上唤醒) - 支持防雷击 / 防 ESD 静电 (华擎全防护) - 支持网线侦测 - 支持高效以太网 802.3az - 支持 PXE
Rear Panel I/O (后面板输入 / 输出接口)	<ul style="list-style-type: none"> - 1 个 PS/2 鼠标接口 - 1 个 PS/2 键盘接口 - 1 个 D-Sub 接口 - 1 个 DVI-D 接口 - 1 个 HDMI 接口 - 4 个可直接使用的 USB 2.0 接口 (支持防 ESD 静电 (华擎全防护)) - 2 个可直接使用的 USB 3.0 接口 (AMD A88X (Bolton-D4)) (支持防 ESD 静电 (华擎全防护)) - 1 个 RJ-45 局域网接口与 LED 指示灯 (ACT/LINK LED 和 SPEED LED) - 高保真音频插孔: 音频输入 / 前置喇叭 / 麦克风
存储	<ul style="list-style-type: none"> - 8 x SATA3 6.0Gb/s 连接头, 支持 RAID (RAID 0, RAID 1, RAID 5 和 RAID 10), NCQ, AHCI 和热插拔功能
连接头	<ul style="list-style-type: none"> - 1 x 机箱开启警告功能接针 - 1 x TPM 接针 - 1 x CPU 风扇接头 (4 针) - 1 x 机箱风扇接头 (4 针) - 1 x 24 针 ATX 电源接头 - 1 x 4 针 12V 电源接头 - 1 x 前置音频面板接头 - 2 x USB 2.0 接口 (可支持 4 个额外的 USB 2.0 接口) (支持防 ESD 静电 (华擎全防护)) - 1 x AMD A88X (Bolton-D4) 的 USB 3.0 接针 (可支持 2 个额外的 USB 3.0 接口) (支持防 ESD 静电 (华擎全防护))
BIOS	<ul style="list-style-type: none"> - 支持图形界面的 64Mb AMI UEFI Legal BIOS - 支持即插即用 (Plug and Play, PnP) - ACPI 1.1 电源管理唤醒功能 - 支持 jumperfree 免跳线模式 - SMBIOS 2.3.1 支持 - DRAM 和 CPU 电压多功能调节器

硬件监控器	<ul style="list-style-type: none"> - CPU 温度侦测 - 机箱温度侦测 - CPU 风扇转速计 - 机箱风扇转速计 - CPU/ 机箱静音风扇 - CPU/ 机箱风扇多速控制 - 机箱开启侦测 - 电压范围: +12V、+5V、+3.3V、核心电压
操作系统	<ul style="list-style-type: none"> - Microsoft® Windows® 8.1 32 位元 /8.1 64 位元 /8 32 位元 /8 64 位元 /7 32 位元 /7 64 位元适用于此主板
认证	<ul style="list-style-type: none"> - FCC, CE, WHQL - 支持 ErP/EuP (需要同时使用支持 ErP/EuP 的电源供应器)

* 请参阅华擎网站了解详细的产品信息：<http://www.asrock.com>

1.3 跳线设置

插图所示的就是设置跳线的方法。当跳线帽放置在针脚上时，这个跳线就是“短接”。如果针脚上没有放置跳线帽，这个跳线就是“开路”。插图显示了一个3针脚的跳线，当跳线帽放置在针脚1和针脚2之间时就是“短接”。

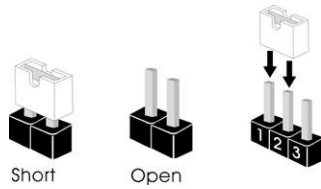

接脚 设定

清除 CMOS

(CLR CMOS1, 3 针脚跳线)
(见第 2 页第 22 项)



注意： CLR CMOS1 允许您清除 CMOS 中的数据。如要清除并将系统参数恢复至默认设置，请关闭计算机，然后从电源插座上拔掉电源线。等待 15 秒后，使用跳线帽将 CLR CMOS1 上的插针 2 和插针 3 短接 5 秒。但是，请勿在更新 BIOS 后立即清除 CMOS。如果需要在更新 BIOS 后立即清除 CMOS，必须在执行 CMOS 清除操作之前，先启动然后关闭系统。请注意，只有取出 CMOS 电池，密码、日期、时间、用户默认配置文件、1394 GUID 和 MAC 地址才会被清除。



如果您清除了 CMOS，机箱开启功能可能会被侦测到。请调节 BIOS 选项“Clear Status”（清除状态）清除之前机箱防盗侦测状态的纪录。

1.4 板载接头和接口



板载接头和接口不是跳线。切勿将跳线帽放置在这些接头和接口上。将跳线帽放置在接头和接口上将会导致主板的永久性损坏！

Serial ATA3 接口

- (SATA_1: 见第 2 页第 16 项)
- (SATA_2: 见第 2 页第 15 项)
- (SATA_3: 见第 2 页第 14 项)
- (SATA_4: 见第 2 页第 13 项)
- (SATA_5: 见第 2 页第 12 项)
- (SATA_6: 见第 2 页第 11 项)
- (SATA_7: 见第 2 页第 9 项)
- (SATA_8: 见第 2 页第 8 项)



这里有八组 Serial ATA3 (SATA3) 接口支持 Serial (SATA) 数据线作为内部储存设置。目前 SATA3 界面理论上可提供高达 6.0Gb/s 的数据传输速率。

USB 2.0 扩展接头

- (9 针 USB_6_7)
- (见第 2 页第 18 项)
- (9 针 USB_8_9)
- (见第 2 页第 19 项)

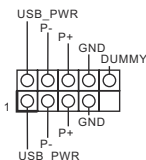

除了位于 I/O 面板的四个默认 USB 2.0 接口之外，这款主板有两组 USB 2.0 接针。这组 USB 2.0 接针可以支持两个 USB 2.0 接口。

USB 3.0 扩展接头

- (19 针 USB_10_11)
- (见第 2 页第 20 项)

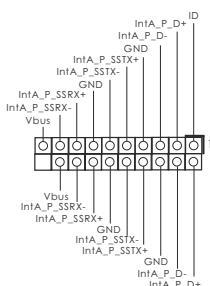

除了位于 I/O 面板的两个默认 USB 3.0 接口之外，这款主板有一组 USB 3.0 接针。这组 USB 3.0 接针可以支持两个 USB 3.0 接口。

前置音频面板接头

- (9 针 HD_AUDIO1)
- (见第 2 页第 21 项)

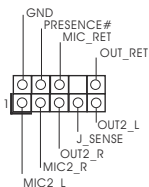

可以方便连接音频设备。



1. 高保真音频 (High Definition Audio, HDA) 支持智能音频接口检测功能 (Jack Sensing), 但是机箱面板的连线必须支持 HDA 才能正常使用。请按我们提供的手册和机箱手册上的使用说明安装您的系统。
2. 如果您使用 AC' 97 音频面板, 请按照下面的步骤将它安装到前面板音频接口:
 - A. 将 Mic_IN(MIC) 连接到 MIC2_L。
 - B. 将 Audio_R(RIN) 连接到 OUT2_R, 将 Audio_L(LIN) 连接到 OUT2_L。
 - C. 将 Ground(GND) 连接到 Ground(GND)。
 - D. MIC_RET 和 OUT_RET 仅用于 HD 音频面板。您不必将它们连接到 AC' 97 音频面板。
 - E. 开启前置麦克风。
在 Windows® 8.1 / 8.1 64 位元 / 8 / 8 64 位元 / 7 / 7 64 位元操作系统中:
在 Realtek 控制面板中点击" FrontMic"。调节" Recording Volume"。

系统面板接头

(9 针 PANEL1)

(见第 2 页第 17 项)

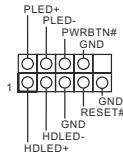

这个接头提供数个系统前面板功能。



根据下面的引脚说明连接机箱上的电源开关、重启按钮与系统状态指示灯到这个排针。根据之前请注意引脚的正负极。

PWRBTN(电源开关):

连接机箱前面板的电源开关。您可以设置用电源键关闭系统的方式。

RESET(重启开关):

连接机箱前面板的重启开关。当电脑死机且无法正常重新启动时, 可按下重启开关重新启动电脑。

PLED(系统电源指示灯):

连接机箱前面板的电源状态指示灯。当系统运行时, 此指示灯亮起。当系统处于 S1 待机模式时, 此指示灯保持闪烁。当系统处于 S3/S4 待机模式或关机 (S5) 模式时, 此指示灯熄灭。

HD LED(硬盘活动指示灯):

连接机箱前面板的硬盘动作指示灯。当硬盘正在读取或写入数据时, 此指示灯亮起。

前面板设计因机箱不同而有差异。前面板模块一般由电源开关、重启开关、电源指示灯、硬盘动作指示灯、喇叭等构成。将您的机箱前面板连接到此排针时, 请确认连接线与针脚上的说明相对应。

机箱喇叭接头
(4 针 SPEAKER1)
(见第 2 页第 7 项)

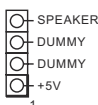

请将机箱喇叭连接到这个接头。

机箱风扇接头
(4 针 CHA_FAN1)
(见第 2 页第 10 项)

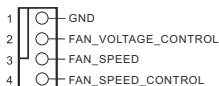

请将风扇连接线接到这个接头，并让黑线与接地的针脚相接。

CPU 风扇接头
(4 针 CPU_FAN1)
(见第 2 页第 2 项)

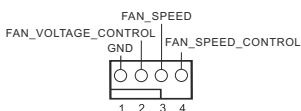

请将 CPU 风扇连接线接到这个接头，并让黑线与接地的针脚相接。



虽然此主板支持 4-Pin CPU 风扇 (Quiet Fan, 静音风扇)，但是没有调速功能的 3-Pin CPU 风扇仍然可以在此主板上正常运行。如果您打算将 3-Pin CPU 风扇连接到此主板的 CPU 风扇接口，请将它连接到 Pin 1-3。

Pin 1-3 连接
3-Pin 风扇的安装

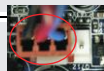

ATX 电源接头
(24 针 ATXPWR1)
(见第 2 页第 5 项)

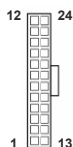

请将 ATX 电源供应器连接到这个接头。



虽然此主板提供 24-pin ATX 电源接口，但是您仍然可以使用传统的 20-pin ATX 电源。为了使用 20-pin ATX 电源，请顺著 Pin 1 和 Pin 13 插上电源接头。

20-Pin ATX 电源安装说明



ATX 12V 接头
(4 针 ATX12V1)
(见第 2 页第 1 项)



请将一个 ATX 12V 电源供应器接到这个接头。

机箱开启警告功能接针

(2 针 C11)

(见第 2 页第 23 项)



本主板支持机箱开启侦测功能，可侦测机箱盖是否被移动。此功能需机箱具备机箱开启侦测设计。

TPM 接针

(17 针 TPMS1)

(见第 2 页第 6 项)

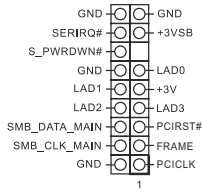

此接头支援信赖平台模组 (TPM) 系统，可确保储存金钥、数位凭证、密码及资料的安全。TPM 系统也能强化网路安全、保护数位身分并确定平台完整性。

电子信息产品污染控制标示

依据中国发布的「电子信息产品污染控制管理办法」及 SJ/T 11364-2006「电子信息产品污染控制标示要求」，电子信息产品应进行标示，藉以向消费者揭露产品中含有的有毒有害物质或元素不致发生外泄或突变从而对环境造成污染或对人身、财产造成严重损害的期限。依上述规定，您可于本产品之印刷电路板上看见图一之标示。图一中之数字为产品之环保使用期限。由此可知此主板之环保使用期限为 10 年。



图一

有毒有害物质或元素的名称及含量说明

若您欲了解此产品的有毒有害物质或元素的名称及含量说明，请参照以下表格及说明。

部件名称	有害物质或元素					
	铅 (Pb)	镉 (Cd)	汞 (Hg)	六价铬 (Cr(VI))	多溴联苯 (PBB)	多溴二苯醚 (PBDE)
印刷电路板及电子组件	X	O	O	O	O	O
外部信号连接接头及线材	X	O	O	O	O	O

O: 表示该有毒有害物质在该部件所有均质材料中的含量均在 SJ/T 11363-2006 标准规定的限量要求以下。

X: 表示该有毒有害物质至少在该部件的某一均质材料中的含量超出 SJ/T 11363-2006 标准规定的限量要求，然该部件仍符合欧盟指令 2002/95/EC 的规范。

备注：此产品所标示之环保使用年限，系指在一般正常使用状况下。

1. 主機板簡介

謝謝你採用了華擎 **FM2A88M Pro3+** 主機板，本主機板由華擎嚴格製造，品質可靠，穩定性好，能夠獲得卓越的性能。此快速安裝指南包括了主機板介紹和分步驟安裝指導。您可以查看支持光碟裡的使用手冊了解更詳細的資料。



由於主機板規格和 BIOS 軟體將不斷更新，本手冊之相關內容變更恕不另行通知。請留意華擎網站上公布的更新版本。你也可以在華擎網站找到最新的顯示卡和 CPU 支援列表。

華擎網址：<http://www.asrock.com>

如果您需要與此主機板有關的技術支援，請參觀我們的網站以了解您使用機種的規格訊息。

www.asrock.com/support/index.asp

1.1 包裝盒內物品

華擎 **FM2A88M Pro3+** 主機板 (Micro ATX 規格)

華擎 **FM2A88M Pro3+** 快速安裝指南

華擎 **FM2A88M Pro3+** 支援光碟

兩條 Serial ATA(SATA) 數據線 (選配)

一塊 I/O 擋板

1.2 主機板規格

架構	<ul style="list-style-type: none"> - Micro ATX 規格 - 固態電容設計 - 高密度防潮纖維電路板
處理器	<ul style="list-style-type: none"> - 支援插座 FM2+ 95W / FM2 100W 處理器
晶片組	<ul style="list-style-type: none"> - AMD A88X (Bolton-D4)
系統記憶體	<ul style="list-style-type: none"> - 支援雙通道 DDR3 記憶體技術 - 4 個 DDR3 DIMM 插槽 - 支援 DDR3 2400+(超頻)2133/1866/1600/1333/1066 non-ECC、un-buffered 記憶體 - 最高支援 64GB 系統容量 - 支援 Intel® Extreme Memory Profile(XMP)1.3/1.2 - 支援 AMD Memory Profile(AMP) 記憶體模組技術,可高達 AMP 2400
擴充插槽	<ul style="list-style-type: none"> - 1 x PCI Express 3.0 x16 插槽 (PCIe1: x16 模式) * PCIe 3.0 僅支援 FM2+ CPU。使用 FM2 CPU 時,僅支援 PCIe 2.0。 - 2 x PCI Express 2.0 x1 插槽 - 支援 AMD 雙顯卡技術
內建顯示	<ul style="list-style-type: none"> - A 系列 APU 整合 AMD Radeon™ R7/R5 系列顯示晶片 - FM2+ CPU 採用 DirectX 11.1、Pixel Shader 5.0。FM2 CPU 採用 DirectX 11、Pixel Shader 5.0。 - 最大共享記憶體 2GB - 支援三個 VGA 輸出選項 :D-Sub、DVI-D 和 HDMI - 支援三台顯示器 - 支援 HDMI, 最高解析度達 4K x 2K (4096x2160) @ 24Hz * 只有 FM2+ APU 可以透過 HDMI 埠支援高達 4096x2160 解析度的顯示器 - 支援 Dual-link DVI-D, 最高解析度達 2560x1600 @ 60Hz - 支援 D-Sub, 最高解析度達 1920x1200 @ 60Hz - 支援 HDMI, 可支援 Auto Lip Sync、Deep Color (12bpc)、xvYCC 與 HBR(高位元率音效)(需具備相容 HDMI 的銀幕) - 支援使用 HDMI 播放藍光立體 3D 影像 - 支援 AMD Steady Video™ 2.0: 最新影像後處理能力,可為家庭 / 線上影像提供自動降低手震的功能 - DVI-D 和 HDMI 接口支援 HDCP 功能 - DVI-D 和 HDMI 接口可播放 1080p 藍光光碟 (BD)
音效	<ul style="list-style-type: none"> - 5.1 CH HD 音訊 (Realtek ALC662 音訊轉碼器) 功能 - 支援防突波 (華擎全防護) - ELNA 音效專用電容

網路功能	<ul style="list-style-type: none"> - PCIE x1 Gigabit LAN 10/100/1000 Mb/s - Realtek RTL8111GR - 支援 Wake-On-WAN - 支援網路喚醒 - 支援防雷擊 / 防 ESD 靜電 (華擎全防護) - 支援網路線偵測功能 - 支援 Energy Efficient Ethernet 802.3az - 支援 PXE
Rear Panel I/O (後背板輸入 / 輸出接口)	<ul style="list-style-type: none"> - 1 個 PS/2 滑鼠接口 - 1 個 PS/2 鍵盤接口 - 1 個 D-Sub 接口 - 1 個 DVI-D 接口 - 1 個 HDMI 接口 - 4 個可直接使用的 USB 2.0 接口 (支援防 ESD 靜電 (華擎全防護)) - 2 個可直接使用的 USB 3.0 接口 (AMD A88X (Bolton-D4)) (支援防 ESD 靜電 (華擎全防護)) - 1 個 RJ-45 區域網接口與 LED 指示燈 (ACT/LINK LED 和 SPEED LED) - 高清晰音效插孔: 音效輸入 / 前置喇叭 / 麥克風
儲存裝置	<ul style="list-style-type: none"> - 8 x SATA3 6.0Gb/s 接頭, 支援 RAID (RAID 0, RAID 1, RAID 5 和 RAID 10), NCQ, AHCI 和熱插拔功能
接頭	<ul style="list-style-type: none"> - 1 x 機殼開啟警告功能接頭 - 1 x TPM 接頭 - 1 x CPU 風扇接頭 (4 針) - 1 x 機箱風扇接頭 (4 針) - 1 x 24 針 ATX 電源接頭 - 1 x 4 針 12V 電源接頭 - 1 x 前置音效接頭 - 2 x USB 2.0 接頭 (可支援 4 個額外的 USB 2.0 接口) (支援防 ESD 靜電 (華擎全防護)) - 1 x AMD A88X (Bolton-D4) 的 USB 3.0 接頭 (可支援 2 個額外的 USB 3.0 接口) (支援防 ESD 靜電 (華擎全防護))
BIOS	<ul style="list-style-type: none"> - 64Mb AMI UEFI Legal BIOS, 具備 GUI 支援 - 支援即插即用 (Plug and Play, PnP) - ACPI 1.1 電源管理喚醒功能 - 支援 jumperfree 免跳線模式 - 支援 SMBIOS 2.3.1 - DRAM、CPU 電壓多功能調節

硬體監控	<ul style="list-style-type: none">- CPU 溫度偵測- 機箱溫度偵測- CPU 風扇轉速計- 機箱風扇轉速計- CPU/ 機箱靜音風扇- CPU/ 機箱風扇多速控制- 機殼開啟偵測- 電壓範圍：+12V, +5V, +3.3V, 核心電壓
操作系統	<ul style="list-style-type: none">- Microsoft® Windows® 8.1 32 位元 /8.1 64 位元 /8 32 位元 /8 64 位元 /7 32 位元 /7 64 位元
認證	<ul style="list-style-type: none">- FCC, CE, WHQL- 支援 ErP/EuP (需要同時使用支援 ErP/EuP 的電源供應器)

* 請參閱華擎網站了解詳細的產品訊息：<http://www.asrock.com>

1.3 跳線設置

插圖所示的就是設置跳線的方法。當跳線帽放置在針腳上時，這個跳線就是“短接”。如果針腳上沒有放置跳線帽，這個跳線就是“開路”。插圖顯示了一個3針腳的跳線，當跳線帽放置在針腳1和針腳2之間時就是“短接”。

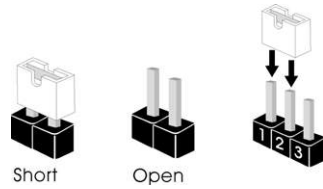

接腳 設定

清除 CMOS

(CLRCMOS1, 3 針腳跳線)
(見第 2 頁第 22 項)



註： CLRCMOS1 可供您清除 CMOS 中的資料。若要清除及重設系統參數並恢復為預設設定，請先關閉電腦電源，並從電源插座中拔下電源線，等待 15 秒鐘之後，使用跳線帽使 CLRCMOS1 的 pin2 及 pin3 短路 5 秒的時間。但請勿於更新 BIOS 後立即清除 CMOS。如需於更新 BIOS 後立即清除 CMOS，您必須先開機再關機，然後再執行 CMOS 清除操作。請注意，只有在移除 CMOS 電池的情況下，密碼、日期、時間、使用者預設設定檔、1394 GUID 及 MAC 位址才會清除。



如果您清除了 CMOS，機殼開啟功能可能會被偵測到。請調整 BIOS 選項“Clear Status”（清除狀態）清除之前機殼防盜偵測狀態的紀錄。

1.4 接頭



此類接頭是不用跳線帽連接的，請不要用跳線帽短接這些接頭。
跳線帽不正確的放置將會導致主機板的永久性損壞！

接頭	圖示	說明
----	----	----

Serial ATA3 接口

(SATA_1: 見第 2 頁第 16 項)

(SATA_2: 見第 2 頁第 15 項)

(SATA_3: 見第 2 頁第 14 項)

(SATA_4: 見第 2 頁第 13 項)

(SATA_5: 見第 2 頁第 12 項)

(SATA_6: 見第 2 頁第 11 項)

(SATA_7: 見第 2 頁第 9 項)

(SATA_8: 見第 2 頁第 8 項)



這裡有八組 Serial ATA3

(SATA3) 接口支援 SATA 數據線作為內部儲存設置。

目前 SATA3 界面理論上

可提供高達 6.0Gb/s 的數據傳輸速率。

USB 2.0 擴充接頭

(9 針 USB_6,7)

(見第 2 頁第 18 項)

(9 針 USB_8,9)

(見第 2 頁第 19 項)

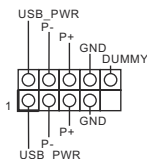

除了位於 I/O 面板的四個

USB 2.0 接口之外，這款

主機板有兩組 USB 2.0 接

針。每組 USB 2.0 接針可以

支援兩個 USB 2.0 接口。

USB 3.0 擴充接頭

(19 針 USB_10,11)

(見第 2 頁第 20 項)

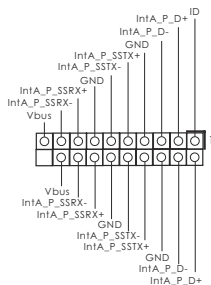

除了位於 I/O 面板的兩個 USB

3.0 接口之外，這款主機板有一

組 USB 3.0 接針。這組 USB 3.0

接針可以支援兩個 USB 3.0 接

口。

前置音效接頭

(9 針 HD_AUDI01)
(見第 2 頁第 21 項)

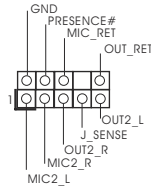

可以方便連接音效設備。



1. 高清晰音效 (High Definition Audio, HDA) 支援智能音效接口檢測功能 (Jack Sensing), 但是機箱面板的連線必須支持 HDA 才能正常使用。請按我們提供的手冊和機箱手冊上的使用說明安裝您的系統。
2. 如果您使用 AC' 97 音效面板, 請按照下面的步驟將它安裝到前面板音效接針:
 - A. 將 Mic_IN(MIC) 連接到 MIC2_L。
 - B. 將 Audio_R(RIN) 連接到 OUT2_R, 將 Audio_L(LIN) 連接到 OUT2_L。
 - C. 將 Ground(GND) 連接到 Ground(GND)。
 - D. MIC_RET 和 OUT_RET 僅用於 HD 音效面板。您不必將它們連接到 AC' 97 音效面板。
 - E. 開啟前置麥克風。
在 Windows® 8.1 / 8.1 64 位元 / 8 / 8 64 位元 / 7 / 7 64 位元作業系統中:
在 Realtek 控制面板中點選" FrontMic"。調整" Recording Volume"。

系統面板接頭

(9 針 PANEL1)
(見第 2 頁第 17 項)

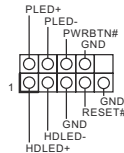

可接各種不同燈, 電源開關及重啟鍵等各種連線。



請根據下面的腳位說明連接機箱上的電源開關、重開按鈕與系統狀態指示燈到這個接頭。請先注意針腳的正負極。

PWRBTN(電源開關):

連接機箱前面板的電源開關。您可以設定用電源鍵關閉系統的方式。

RESET(重開開關):

連接機箱前面板的重開開關。當電腦當機且無法正常重新啟動時, 可按下重開開關重新啟動電腦。

PLED(系統電源指示燈):

連接機箱前面板的電源狀態指示燈。當系統運行時, 此指示燈亮起。當系統處於 S1 待命模式時, 此指示燈保持閃爍。當系統處於 S3/S4 待命模式或關機 (S5) 模式時, 此指示燈熄滅。

HD LED(硬碟活動指示燈):

連接機箱前面板的硬碟動作指示燈。當硬碟正在讀取或寫入數據時，此指示燈亮起。

前面板設計因機箱不同而有差異。前面板模組一般由電源開關、重開關、電源指示燈、硬碟活動指示燈、喇叭等構成。將您的機箱前面板連接到此接頭時，請確認連接線與針腳上的說明相對應。

機箱喇叭接頭

(4 針 SPEAKER1)
(見第 2 頁第 7 項)

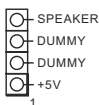

請將機箱喇叭連接到這個接頭。

機箱風扇接頭

(4 針 CHA_FAN1)
(見第 2 頁第 10 項)

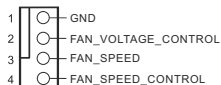

請將風扇連接線接到這個接頭，並讓黑線與接地的針腳相接。

CPU 風扇接頭

(4 針 CPU_FAN1)
(見第 2 頁第 2 項)

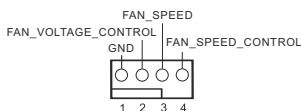

請將 CPU 風扇連接線接到這個接頭，並讓黑線與接地的針腳相接。



雖然此主板支持 4-Pin CPU 風扇 (Quiet Fan, 靜音風扇)，但是沒有調速功能的 3-Pin CPU 風扇仍然可以在此主板上正常運行。如果您打算將 3-Pin CPU 風扇連接到此主板的 CPU 風扇接口，請將它連接到 Pin 1-3。

Pin 1-3 連接 ←
3-Pin 風扇的安裝

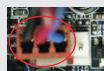

ATX 電源接頭

(24 針 ATXPWR1)
(見第 2 頁第 5 項)

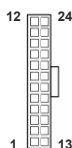

請將 ATX 電源供應器連接到這個接頭。



雖然此主機板提供 24-pin ATX 電源接口，但是您仍然可以使用傳統的 20-pin ATX 電源。為了使用 20-pin ATX 電源，請順著 Pin 1 和 Pin 13 插上電源接頭。

20-Pin ATX 電源安裝說明



ATX 12V 電源接口

(4 針 ATX12V1)
(見第 2 頁第 1 項)



請注意，必需將帶有 ATX 12V 插頭的電源供應器連接到這個插座，這樣就可以提供充足的電力。如果不這樣做，就會導致供電故障。

機殼開啟警告功能接頭

(2 針 C11)
(見第 2 頁第 23 項)



此主機板支援機殼開啟偵測功能，可偵測機殼蓋是否被移動。此功能需機殼具備機殼開啟偵測設計。

TPM 接針

(17 針 TPMS1)
(見第 2 頁第 6 項)

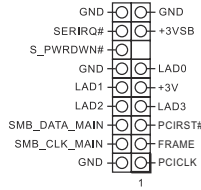

此接頭支援信賴平台模組 (TPM) 系統，可確保儲存金鑰、數位憑證、密碼及資料的安全。TPM 系統也能強化網路安全、保護數位身分並確定平台完整性。



Spesifikasi

Podium	<ul style="list-style-type: none"> - Faktor Form Mikro ATX - Desain Kapasitor Solid - PCB Struktur Kaca Kepadatan Tinggi
CPU	- Didukung untuk prosesor Socket FM2+ 95W/FM2 100W
Grup Chip	- AMD A88X (Bolton-D4)
Ingatan	<ul style="list-style-type: none"> - Teknologi ingatan DDR3 dwisalurkan - 4 x Alur DDR3 DIMM - Menggunakan DDR3 2400+(OC)/2133/1866/1600/1333/1066 - Kapasitas paling banyak: 64GB - Mendukung Intel® Extreme Memory Profile (XMP)1.3/1.2 - Mendukung Teknologi AMD Memory Profile (AMP)hingga AMP 2400
Alur Ekspansi	<ul style="list-style-type: none"> - 1 x PCI Express 3.0 x16 slots (PCIe1: x16 mode) * PCIe 3.0 hanya didukung dengan FM2+ CPU. Dengan FM2 CPU, hanya mendukung PCIe 2.0. - 2 x PCI Express 2.0 x1 slot - Mendukung AMD Dual Graphics
Diagram	<ul style="list-style-type: none"> - Grafis seri AMD Radeon™ R7/R5 terintegrasi di APU seri A - DirectX 11.1, Pixel Shader 5.0 dengan FM2+ CPU. DirectX 11, Pixel Shader 5.0 dengan FM2 CPU. - Ingatan sama Max. 2GB - Tiga pilihan VGA Output: D-Sub, DVI-D dan HDMI - Mendukung Triple Monitor - Mendukung HDMI Technology dengan resolusi maksimal hingga 4K x 2K (4096x2160) @ 24Hz * Hanya FM2 + APU dapat mendukung hingga 4096x2160 resolusi layar melalui port HDMI - Mendukung Dual-link DVI-D dengan resolusi maksimal hingga 2560x1600 @ 60Hz - Mendukung D-Sub dengan resolusi maksimal hingga 1920x1200 @ 60Hz - Mendukung Auto Lip Sync, Deep Color (12bpc), xvYCC dan HBR (High Bit Rate Audio) dengan HDMI (memerlukan monitor HDMI yang kompatibel) - Mendukung Blu-ray Stereoscopic 3D dengan HDMI - Mendukung AMD Video™ 2.0 Tenang: Baru video pasca kemampuan pengolahan untuk pengurangan jutter otomatis pada rumah / online video

	<ul style="list-style-type: none"> - Mendukung fungsi HDCP dengan port DVI-D dan HDMI - Mendukung pemutaran 1080p Blu-ray (BD) dengan port DVI-D dan HDMI
Audio	<ul style="list-style-type: none"> - Audio HD 5.1 CH (Realtek ALC662 Audio Codec) - Mendukung Perlindungan Lonjakan Arus (ASRock Full Spike Protection) - ELNA Audio Caps.
LAN	<ul style="list-style-type: none"> - PCIE x1 Gigabit LAN 10/100/1000 Mb/s - Realtek RTL8111GR - Mendukung Wake-On-WAN - Mendukung Wake-On-LAN - Mendukung Perlindungan Lonjakan Arus (ASRock Full Spike Protection) - Mendukung Deteksi Kabel LAN - Mendukung Energy Efficient Ethernet 802.3az - Mendukung PXE
Papan Belakang I/O	<ul style="list-style-type: none"> - 1 x Port Mouse PS/2 - 1 x Port Keyboard PS/2 - 1 x Port D-Sub - 1 x Port DVI-D - 1 x Port HDMI - 4 x Port USB 2.0 siap-dipakai (Mendukung Perlindungan ESD (ASRock Full Spike Protection)) - 2 x Port USB 3.0 siap-dipakai (AMD A88X (Bolton-D4)) (Mendukung Perlindungan ESD (ASRock Full Spike Protection)) - 1 x RJ-45 LAN Port LED (ACT/LINK LED dan SPEED LED) - HD Audio Jack: Line in / Penyuaran Depan / mikropon
Penyimpanan	<ul style="list-style-type: none"> - 8 x penghubung SATA3 6.0Gb/s, dapat digunakan RAID (RAID 0, RAID 1, RAID 5 dan RAID 10), NCQ, AHCI dan fungsi fungsi "Hot Plug"
Penghubung	<ul style="list-style-type: none"> - 1 x Chassis Intrusion header - 1 x header TPM - 1 x Penghubung KIPAS CPU (4 pin) - 1 x Penghubung KIPAS casing (4 pin) - 1 x Penghubung power 24 pin ATX - 1 x Penghubung power 4 pin 12V - 1 x Penghubung audio panel depan - 2 x USB 2.0 header (menggunakan 4 port USB 2.0) (Mendukung Perlindungan ESD (ASRock Full Spike Protection))

	<ul style="list-style-type: none"> - 1 x USB 3.0 header melalui AMD A88X (Bolton-D4) (menggunakan 2 port USB 3.0) (Mendukung Perlindungan ESD (ASRock Full Spike Protection))
Ciri-ciri BIOS	<ul style="list-style-type: none"> - 64Mb AMI UEFI Legal BIOS dengan dukungan GUI - Menggunakan "Plug and Play" - ACPI 1.1 Compliance Wake Up Events - Menggunakan jumperfree - Penyokong AMBIOS 2.3.1 - Penyesuaian berbagai tegangan DRAM dan CPU
Penjaga Hardware	<ul style="list-style-type: none"> - Perasa Suhu CPU - Perasa Suhu Casis - Pengukur Kipas CPU - Pengukur Kipas Casis - Kipas diam CPU/Casis - Kontrol Multi-Kecepatan Kipas CPU/Casis - Deteksi CASING TERBUKA - Penjagaan voltasi: +12V, +5V, +3.3V, Vcore
OS	<ul style="list-style-type: none"> - dapat digunakan Microsoft® Windows® 8.1 32-bit / 8.1 64-bit / 8 32-bit / 8 64-bit / 7 32-bit / 7 64-bit
Sertifikasi	<ul style="list-style-type: none"> - FCC, CE, WHQL - ErP/EuP Ready (memerlukan catu daya ErP/EuP ready)

* Untuk informasi rinci, silakan kunjungi website kami: <http://www.asrock.com>

Contact Information

If you need to contact ASRock or want to know more about ASRock, you're welcome to visit ASRock's website at <http://www.asrock.com>; or you may contact your dealer for further information. For technical questions, please submit a support request form at <http://www.asrock.com/support/tsd.asp>

ASRock Incorporation

2F., No.37, Sec. 2, Jhongyang S. Rd., Beitou District,

Taipei City 112, Taiwan (R.O.C.)

ASRock EUROPE B.V.

Bijsterhuizen 3151

6604 LV Wijchen

The Netherlands

Phone: +31-24-345-44-33

Fax: +31-24-345-44-38

ASRock America, Inc.

13848 Magnolia Ave, Chino, CA91710

U.S.A.

Phone: +1-909-590-8308

Fax: +1-909-590-1026